

SERVICE



BULLETIN

OLIVER OUTBOARD MOTORS

DIVISION OF OLIVER CORPORATION

108 SOUTH McCAMLY STREET • BATTLE CREEK, MICHIGAN

May 20, 1959
SM-1-63

TO: All Distributors and Dealers

SUBJECT: Preventative Maintenance

Since introduction of the present outboard motors, it has been found that many customers place the motors into immediate use without taking the required time to read the operators manual. Probably the greatest abuse to the outboard motor is within the first ten hours of operation due to operating the new unit at full throttle right at the outset. No one operates their new automobile in this manner. Usually every owner is careful not to exceed a certain speed for the first few thousand miles to assure a proper motor break-in.

This same discriminating care should be given to an outboard motor. There should be a break-in period extending to approximately ten hours when the operator should not operate his motor at full throttle for extended periods of time. For the 6 and 16 HP engines, approximately three (3) tanks of fuel with extra oil added should be used. For the 35 HP engine, approximately five (5) tanks of fuel with extra oil will be required. An outboard motor is similar to an automotive four cycle engine, built with precision and close tolerances. The moving parts should be given sufficient time to "wear in" for long life and best performance.

It is recommended policy to use 3/4 pint of oil to each gallon of gasoline in all Oliver Outboard Motors for the first ten hours of operation. Do not expect good idle performance during the break-in period. If you are using the Mix-Matic Fuel Tank, fill the oil container portion twice when adding gasoline.

Service Department

CAA:dd

C-3955-A84

SERVICE



BULLETIN

OLIVER OUTBOARD MOTORS

DIVISION OF OLIVER CORPORATION

108 SOUTH McCAMLY STREET • BATTLE CREEK, MICHIGAN

May 13, 1959
SM-1-62

TO: All Distributors and Dealers

SUBJECT: Cylinder Block and Crankcase Assembly - Part #498 683JS
For Model J3, J4, and J5 Motors.

In an effort to furnish you with quick repair parts in the form of a sub-assembly, we have on hand a limited supply of Part #498 683JS Cylinder Block and Crankcase assemblies with .010" oversize main bearing bore. These assemblies are furnished with main bearings to fit the oversize bore in the block and crankcase. This oversize does not effect the crankshaft. The crankshaft is standard size.

Referenced cylinder block assemblies may be identified by the block serial number located on the intake side of the block between the two cylinders. The number range is J-10501 to J-10851.

The following dimensions are furnished for the purpose of checking:

Standard cylinder block main bearing bore size is .9516 - .9511".
Oversize cylinder block main bearing bore size is .9616 - .9611".
Outside diameter of standard main bearings is .9508 - .9513".
Outside diameter of oversize main bearings is .9608 - .9613".
Inside diameter is the same for standard and oversize main bearings .8280 - .8290".

In referenced cylinder block assemblies, bearing part number changes are as follows:

1	#492 139J	Upper Main Bearing	Replaces	#492 135J
1	492 137J	Center Main Bearing	"	492 040J
1	492 138J	Center Main Bearing	"	492 041J
1	492 140J	Lower Main Bearing	"	492 136J

Before ordering new parts, be sure to check the block serial numbers.

Service Department

CAA:dd

C-39 55- A83

SERVICE



BULLETIN

OLIVER OUTBOARD MOTORS

DIVISION OF OLIVER CORPORATION

108 SOUTH McCAMLY STREET • BATTLE CREEK, MICHIGAN

May 12, 1959
SM-1-61

TO: All Distributors and Dealers

SUBJECT: Conversion of the 5 $\frac{1}{2}$ HP to 6HP.

In our endeavor to make available the latest engineering improved parts for previous model years, requires some modifications.

As a replacement part for the Model J2, Cylinder Block and Crankcase Assembly, Part #492 025JYS, use Part #498 667JS Cylinder Block and Crankcase Assembly with the following parts and modifications:

1	#492 117JS	Intake Manifold Assembly
2	492 115J	Stud-Center Main
1	492 122J	Bracket-Cam Throttle
1	492 127JS	Choke Rod Assembly
1	492 067J	Spring-Choke Knob (Cut in half)

Remove 11/16" from the adjustment knob end of the hi and low speed carburetor adjustment shafts. All other parts are interchangeable. This will make a 6HP engine.

The former 5 $\frac{1}{2}$ HP cylinder blocks, Part #492 025JYS are no longer available.

Service Department

RDM:dd

C-3955-A02

SERVICE



BULLETIN

OLIVER OUTBOARD MOTORS

DIVISION OF OLIVER CORPORATION

108 SOUTH McCAMLY STREET • BATTLE CREEK, MICHIGAN

May 12, 1959
SM-1-60

TO: All Distributors and Dealers

SUBJECT: Warranty Claim Procedure

We are embarking on a new method of handling warranty claim procedure to assure quick action. This procedure will be placed into effect immediately.

Please note the new warranty claim report Form C-4169. It has been carefully designed to get all of the information back to Oliver for an immediate disposition of the claim. The warranty claim report card C-4213 is used by Oliver to indicate disposition of warranty parts. The entire warranty plan is designed to simplify the disposition of warranty material and to expedite issuing credit.

The only deviation from the standard procedure is where a dealer is dealing directly with Oliver because a distributor is not established in his area. In such instances, the dealer will assign a claim number and send the claim report directly to Oliver. The claim will be analyzed by Oliver. The dealer will be advised its disposition on our warranty claim report card C-4213.

In instances of this nature where no distributor exists, dealer claims will be honored in the same manner as that of a distributor. As servicing distributors are finalized, the dealer will be advised accordingly and no further claims will be accepted and handled on a direct basis between the dealer and The Oliver Outboard Division.

Each dealer that does not have a distributor in his area, should request a quantity of the C-4169 warranty claim report forms from Oliver immediately.

Service Department

WARRANTY SERVICE
AND
CLAIM PROCEDURE

OLIVER OUTBOARD MOTOR WARRANTY

Oliver Outboard Motors are warranted to be free from defects in material or workmanship under normal use and service. The Oliver Corporation's and distributor's obligation under this warranty shall be limited to replacing or repairing any part or parts which shall disclose defects within three (3) months after initial use or within one (1) year after date of original purchase, whichever occurs first, and which upon examination, The Oliver Corporation and distributor shall determine to be defective or not up to specifications: Provided that owner or dealer shall make claim thereon and return said part or parts to distributor, transportation prepaid, within the warranty period or within 10 days thereafter.

This warranty shall not apply to any Oliver Outboard Motor or part sold by the Oliver Corporation, which shall have been altered or repaired outside of the facilities of The Oliver Corporation, or which has been subjected to misuse, neglect or accident. We make no warranty for accessories as they are purchased and are usually warranted separately by their respective manufacturers. Because of unusual strains inherent in their use, we make no warranty of either material or workmanship in racing outboard motors.

This warranty is made in lieu of all other warranties, expressed or implied, and no warranty is made or authorized to be made, other than herein set forth. In no event shall The Oliver Corporation's liability on any expressed or implied warranty exceed the replacement cost F.O.B. point of shipment, of parts found by The Oliver Corporation and distributor to be defective.

A warranty registration card accompanies every motor from Oliver. Your dealer has been instructed to fill out this card and send the designated portion to Oliver; he is also instructed to give you the stub attached thereto.

WARRANTY REPAIRS

All warranty repairs are normally performed by authorized service dealers and distributors except when field failures are returned to Oliver for inspection.

A simplified warranty procedure is based on fast repair for the customer and the least amount of work for the serviceman performing the job.

Complete details of the warranty are outlined in the Warranty Service and Claim Procedure.

The distributor and dealer is obligated to furnish warranty labor and Oliver is to allow credit or replace warranty parts.

On any unusual problem, Oliver is always willing to consider assistance to the dealer or distributor upon full discussion of details involved.

WARRANTY SERVICE AND CLAIM PROCEDURE

It is necessary to have a guide for any that is successful. The Warranty Claim Form Procedure outlines the basis for operation between the distributor, dealer and The Oliver Outboard Division of The Oliver Corporation.

We believe this is a clearly outlined policy which is fair and equitable to all parties concerned.

We invite you to carefully read and discuss the contents.

WATERCRAFTMANUALS.COM

PARTS AND SERVICE NOT INCLUDED UNDER WARRANTY

A failure due to the first five listed causes is not considered under the warranty provisions. Our warranty does not cover normal service requirements that may arise during the warranty period as defined in the last four items.

1. Alterations or repair by anyone other than the distributor, it's authorized dealers, or authorized service outlet.
2. Has been subjected to misuse, accident, neglect, alteration or used for racing purposes.
3. Not operated or maintained in accordance with printed operating and care instructions furnished with each motor or accessory.
4. Has been submerged or not drained properly, permitting water or foreign material to enter operating parts.
5. Damage in transit.
6. Cleaning, adjusting, or replacing such items as spark plugs.
7. Repair or replacement of parts due to normal wear.
8. Parts or labor required to repair engines previously serviced by unauthorized person or persons.
9. Additional service work, such as painting, etc., requested by the owner over and above the repair and replacement of defective material or work performed due to defective workmanship.

All of the above are not included under warranty.

WARRANTY ADJUSTMENT PROCEDURE

Any part or parts of an outboard motor or an accessory which is manufactured by us and proved to be defective in either material or workmanship under the terms of warranty, will be replaced by the company under the terms of warranty, provided such part or parts are proved to the company's satisfaction to be defective when handled in accordance with the following procedure:

1. Warranty claim report is processed and filled out with complete information and forwarded to the company in accordance with instructions contained herein under the heading of "Warranty Claim Form Procedure".
2. All defective parts replaced are retained by the authorized distributor until disposition is received from Oliver.
No motor or parts are to be shipped back to Oliver without first obtaining permission to do so. Such shipments must be prepaid.
3. The owner is obligated to furnish supporting evidence of warranty status by warranty registration card, or bill of sale covering the purchase of the outboard motor or accessory. The company retains the prerogative of requesting such supporting evidence in conjunction with any warranty claim.
4. If the warranty claim is in doubt, an authorized distributor, through his dealer, may advise the customer, charging the customer for replacement of parts, but may submit a claim form to the factory for review under these circumstances. The distributors agree to reimburse the customer through his dealer, should the claim be accepted by the Company.
5. Defining replacement of parts can be assumed to fall into two categories:
 - A. Physical replacement of defective part on a "no-charge" basis.
 - B. Credit issued to cover the distributor's cost of replacing the defective part. The normal procedure in handling replacement parts shall fall in category (B).

WARRANTY CLAIM FORM PROCEDURE

All claims must be submitted to the company on a warranty claim report form number C-4169. The form must be filled out completely and in detail, and properly signed by the distributor or his authorized representative performing the warranty work. A claim number should be assigned by the distributor to coincide with his accounting system. The company retains the sole right of determining the validity of the claim or its approval.

THE WARRANTY CLAIM REPORT PROCEDURE IS AS FOLLOWS:

- I. The warranty claim report will be made out in quadruplicate. Two copies to be mailed to Oliver, one to be retained by the service department and the second to go to the accounting department. The two Oliver copies are to be mailed to the attention of the service manager. The third copy to be retained by the distributor. The fourth copy to go to the dealer. Each warranty claim report submitted is to cover repair of one unit only. After the warranty claim report has been received and reviewed by the service department, disposition will be given by a warranty claim report card.

WARRANTY CLAIM REPORT

No. Date:
Motor Serial No:
Credit Authorized:
Hold Material for Oliver Rep.
Return Material to Oliver:
Dispose of Material at Source:

Comments:

This form includes claim number, date, motor serial number and disposition. There are four categories under disposition.

1. Credit Authorized: A check mark in the box indicates credit is authorized immediately.
2. Hold Material for Oliver Representative: It is possible to have credit authorized and also have a check mark to hold material for Oliver Representative. There may be some instances when it will be desirable to have a regional sales manager or a field service representative analyze the material.
3. Return Material to Oliver: A check mark in this block indicates Oliver wants the material returned, transportation collect, and no credit will be issued until the parts have arrived at the plant, been analyzed and decision made as to their condition.

4. Dispose of Material at Source: A check mark in this block is authorization to scrap the parts where they are located. The parts should be mutilated to eliminate possible reuse. The "Credit Authorized" block will also be checked advising that credit is being issued.

There may be instances when a check mark will appear in one of the last three categories, but under "Comments" will be special requests.

Example #1: Return material to Oliver is checked on the card and under normal circumstances, all defective parts would be returned to Oliver. In some instances it would be advisable to scrap heavy items at the source and return only those items that are required for analysis. Therefore under "Comments" may read, "Scrap crankshaft and crankcase at source".

Example #2: Dispose of material at source is checked. Normally all of the items listed on the report would be scrapped at its source and nothing returned to Oliver. In isolated cases a vendor may require certain parts returned for examination or to verify failure before credit may be issued by the vendor to Oliver. In that event, under "Comments" shall indicate, "carburetor and fuel pump to be returned to Oliver".

- II. Warranty claim reports are to be sent to Oliver immediately after repairs are completed. The company retains the right to refuse warranty claims unless received thirty days from date of repair.
- III. When the company accepts the claim as outlined, Oliver will issue credit to cover the authorized distributor's cost of such defective parts as were replaced under the terms of the claim. Credit for parts will be handle by the factory directly with the distributor, and not through dealers or customers.
- IV. Deductions from any remittance submitted to the company shall not be made for any claim until a proper credit memo has been received by the distributor in settlement of such claim.



WARRANTY CLAIM REPORT

CLAIM NO. _____

Distributor _____ Date of this Report _____

Dealer _____ Address _____ Date of Purchase by Dealer _____

Owner _____ Address _____ Date of Purchase by User _____

Fresh Water Use Serial Number _____ principal Assembly
Salt Water Use Model _____ Number _____ involved _____

Approximate Hours in Service _____ Has Warranty Card been sent to Factory _____ Date Corrected _____

Motor used for: Fishing Water Skiing Commercial Racing

Type of Boat and Horsepower Rating _____

Describe Trouble or Breakage and Correction Applied. Do not say it broke

Probable Cause of Failure: _____

PARTS USED TO CORRECT:

QTY.	PART NO.	DESCRIPTION	QTY.	PART NO.	DESCRIPTION

Signed: _____ Dealer _____ Distributor _____

Dealer and/or Distributor signature on this form attests that the foregoing information is true to the best of their knowledge and belief.

Authorization for Credit Approved _____ Service Manager - Oliver Outboard Motors

- INSTRUCTIONS:**
- All parts removed from the engine covered on this report, must be kept and tagged at the distributor until disposition is given by The Oliver Corporation.
 - Fill in report in quadruplicate. Two copies to Factory. One copy to Dealer. One copy for Distributor.
 - A separate report must be issued with each warranty claim.
 - Warranty claim report must be filed within 30 days after repair was made.

COMMENTS _____

FACTORY USE ONLY

Credit Authorized

Hold Material for Oliver Rep.

Return Material to Oliver

Dispose of Material at Source

Accounting Reference

SERVICE



BULLETIN

OLIVER OUTBOARD MOTORS

DIVISION OF OLIVER CORPORATION

108 SOUTH McCAMLY STREET • BATTLE CREEK, MICHIGAN

May 12, 1959
SM-1-59

TO: All Distributors and Dealers

SUBJECT: Outboard Motor Tune-Up

Tune up work on outboard motors can be a very profitable part of your business.

All two (2) cycle engines inherently collect carbon in the combustion chamber due to the oil for lubrication mixed with the fuel. This also causes gum and varnish to collect on the side of the piston.

When spark plug life becomes short, it is necessary to clean these foreign materials from inside the engine. This can be accomplished by an engine cleaner. Our recommendation is the Marine Care Outboard Engine Tune-Up, manufactured by Ralph Shrader Inc., Whittier, California. This cleaner has proven in our factory tests to do an excellent job in removing gum and varnish from the side of the piston. It is necessary to remove the cylinder head and scrape or brush the carbon deposits from the combustion chamber. When this foreign material has been removed, it will bring the spark plug life back to normal.

A satisfied customer means additional future sales. This is accomplished by giving the customer the type of service work they expect.

Service Dept.

RDM:dd

C-3955-A80

SERVICE



BULLETIN

OLIVER OUTBOARD MOTORS

DIVISION OF OLIVER CORPORATION

108 SOUTH McCAMLY STREET • BATTLE CREEK, MICHIGAN

April 14, 1959
SM-1-58

TO: All Distributors and Dealers

SUBJECT: Oliver Outboard Motor Suggested Flat Rate Service Labor Guide

The Oliver Flat Rate Labor Guide which is attached, was prepared to assist servicing dealers in determining labor time for various service operations on Oliver Outboard Motors. This guide will make it possible to quickly estimate the cost of repairs for each service job.

Each operation in the Flat Rate Labor Guide was performed a sufficient number of times until a good average time was determined. The chart is based on the time required to perform the operation by a qualified mechanic, with the use of Oliver Special Tools and equipment covered in our bulletin SM-1-50 dated October 27, 1958.

The time shown includes testing of the motor after the work is completed. When several items are involved in an operation, the time shown includes the individual operations. For example; Replacement of cylinder block and crankcase assembly, includes replacement of crankshaft, piston, rod, and etc. and no additional labor time should be included beyond the figure shown in the charts. The time allowances are sufficient to perform the work properly.

We believe you will find this guide to be of real value in arriving at the charges to be made to your customers. The fact that you have an actual factory approved labor time for various service operations, will be helpful in your customer relations. Remember, fair charges are important to both you and your customer.

We would appreciate your comments on this chart. We are anxious to be helpful in developing your service program for profit to you.

Service Department

RDM:dd

C-3955-A79

PRINTED
IN
U.S.A.

**OLIVER OUTBOARD MOTOR
SUGGESTED FLAT RATE SERVICE LABOR GUIDE**

REPLACEMENT OF:	6 HP	16 HP	16 HP-E	35 HP
Bearings- Powerhead	3	4	4	5
Cylinder block & Crankcase	3	4	4	5
Crankshaft	2-1/2	3-1/2	3-1/2	4-1/2
Pistons - Rings - Rods	3	3-1/2	3-1/2	5
Gaskets and Seals	1	1-1/2	1-1/2	2
Cylinder Head Gasket only	1/2	1/2	1/2	1
Carburetor (new)	3/4	1	1-1/4	1-1/2
Carburetor (repair)	1-1/4	1-1/2	1-3/4	2
Carburetor Gasket	3/4	1	1-1/2	1-1/2
Intake Manifold - Reeds or Valves	1	1-1/2	1-3/4	2-1/2
Magneto (new)	1	1	1	1
Coils- Hi-Tension	1	1	1	1/2
Condenser	1	1	1	3/4
Breaker points	1	1	1	3/4
Flywheel	1/2	1/2	1/2	1/2
Water Tube (including Cyl. Head Gasket.)	1	1	1	1-1/2
Carrying Handle and/or Pivot Tube	1	1	1	1
Steering Handle	1/2	1/2	1/2	----
Water pump parts	3/4	1	1	3/4
Gear Housing	2	3	3	2-1/2
Gears and Component parts	2	3	3	3
Driveshaft	3/4	2	2	3/4
Stern Bracket	1/2	1/2	1/2	1
Swivel Bracket	1-1/2	1-1/2	1-1/2	1-1/2
Starter (new)	1/4	1/4	1/4	----
Starter Housing	1/2	1/2	1/2	----
Starter Spring (Rewind)	3/4	3/4	3/4	----
Pawls and Spring	1/2	1/2	1/2	----
Rope	1/2	1/2	1/2	----
Electric starter	----	----	1	1-1/2
Starter solenoid	----	----	1/4	1/2
Choke Solenoid	----	----	1/4	1/4
Brushes - Starter	----	----	2	2-1/2
Fuel pump	1/2	3/4	3/4	1
Shrouds (All Top-Front and Bottom)	1/4	1/2	1/2	3/4
Generator	----	----	----	1

Oliver outboard motor Division
Battle Creek, Michigan

NOTE: Time shown includes testing. Where several items are included, time shown covers all operations..
For Example; - Replacement of cylinder block and crankcase assembly, includes replacement of crankshaft, piston, rod, rings, etc., with no additional labor time.

SERVICE



BULLETIN

OLIVER OUTBOARD MOTORS

DIVISION OF OLIVER CORPORATION

108 SOUTH McCAMLY STREET • BATTLE CREEK, MICHIGAN

March 24, 1959
SM-1-57

TO: All Oliver Outboard Motor Distributors and Dealers

SUBJECT: Stolen Motor K2E-9247

Please be advised subject motor has been reported stolen from,
Mr. Rocco Rampini, 132 Chandler Street, Cranston, Rhode Island.

Should you obtain any information regarding this motor, please
contact this office or Mr. Rampini.

Service Department

CAA:dd

C-3955-A78



SERVICE

BULLETIN

OLIVER OUTBOARD MOTORS

DIVISION OF OLIVER CORPORATION

108 SOUTH McCAMLY STREET • BATTLE CREEK, MICHIGAN

SM-1-41
Aug. 22, 1958

TO: All Oliver Outboard Motor Distributors and Dealers

SUBJECT: Stolen Motors - B2-305344 - K4E-275884 - K4-202953

Please be advised subject motors have been reported as stolen from

A. J. Boellner, Maumee, Ohio.

Should you obtain any information regarding these motors please contact
this office or Mr. Boellner.

C-3955-A61

SERVICE



BULLETIN

OLIVER OUTBOARD MOTORS

DIVISION OF OLIVER CORPORATION

108 SOUTH McCAMLY STREET • BATTLE CREEK, MICHIGAN

SM-1-40
Aug. 22, 1958

TO: All Oliver Outboard Motor Distributors and Dealers

SUBJECT: Stolen Motor - B2-303306

We have been advised subject motor has been stolen from Phaff of Toledo,
218 Main Street, Toledo 5, Ohio.

Should you obtain any information regarding this motor, please contact
this office or the above dealer.

C-3955-A60

SERVICE



BULLETIN

OLIVER OUTBOARD MOTORS

DIVISION OF OLIVER CORPORATION

108 SOUTH McCAMLY STREET • BATTLE CREEK, MICHIGAN

SM-1-56
April 6, 1959

TO: All Oliver Outboard Motor Distributors and Dealers

SUBJECT: Parts List and Assembly Instructions for 1959 Throttle and Shift Remote Control Boxes and Control Cables. (Order Remote Control Assemblies by Assembly Number).

MODEL	ASSY. NO.	DESCRIPTION
MBSS	498 901JS	Oliver Single Lever Control Box Assembly -Starboard - RH-For 35 HP Olympus, Complete with #498 904JS Motor Adaption Kit.
MBPS	498 902JS	Oliver Single Lever Control Box Assembly - Port-LH-For 35 HP Olympus, Complete with #498 904JS Motor Adaption Kit. NOTE: For Starboard-RH or Port LH Twin 35 HP Motor, Single Lever Control, Order (1) #498 901JS, (1) 498 902JS Controls and (3) AD 021 Screws. Use the (3) Screws to fasten the two controls together for dual installation.
MBUT	498 800JS	Oliver two lever Control Box Assembly - Complete with motor adaption kit for 35 HP Olympus. (Includes #498 900JS Two Lever Control Box and #498 904JS Motor Adaption Kit).
MKUT	498 801JS	Oliver Two Lever Control Box Assembly - Complete with Motor Adaption Kit for 16 HP Motor. (Includes #498 900JS Two Lever Control Box and #498 903JS Motor Adaption Kit).
HBST	498 737JS	Synchro-Matic Two Lever Control - Complete with Cable end fittings and Steering adapter for 35 HP Olympus. (See Service Bulletin SM-1-39 for parts list and assembly instructions).
HBPT		Order #498 737JS and reassemble for Port -LH Installation. (See Service Bulletin SM-1-39).
HBDS	498 744JS	Dual Synchro-Matic Two Lever Control complete with cable end fittings and steering adapters for twin 35 HP Olympus motors, Starboard-RH mounting. (See Service Bulletin SM-1-39 for Parts List and Assembly Instructions).

MODEL	ASSY. NO.	DESCRIPTION
HBDP	498 745JS	Dual Synchro-Matic Two-Lever Control, complete with cable end fittings and Steering Adapters for twin 35 HP Olympus Motors, Port-LH mounting. (See Service Bulletin SM-1-39 for Parts List and Assembly Instructions).
HKUT	498 748JS	Synchro-Matic Two-Lever Control, complete with cable end fittings, steering adapter, and motor mounting brackets for 6 and 16 HP motors, Port or Starboard Mounting.
HKDJ	498 750JS	Dual Synchro-Matic Two-Lever Control complete with cable end fittings, steering adapters, and motor mounting brackets for twin 6 or 16 HP motors, Port or Starboard mounting.

CONTROL CABLE TYPE 33-S - USE WITH MODELS MBSS-MBPS-MBUT and MKUT.

CONTROL CABLE TYPE S USE WITH MODELS HBST-HBPT-HBDS-HBDP-HKUT and HKDJ.

498 906JS	Remote Cable Assy. 6'
498 907JS	Remote Cable Assy. 7'
498 908JS	Remote Cable Assy. 8'
498 909JS	Remote Cable Assy. 9'
498 910JS	Remote Cable Assy. 10'
498 911JS	Remote Cable Assy. 11'
498 912JS	Remote Cable Assy. 12'
498 913JS	Remote Cable Assy. 13'
498 914JS	Remote Cable Assy. 14'
498 915JS	Remote Cable Assy. 15'
498 916JS	Remote Cable Assy. 16'
498 917JS	Remote Cable Assy. 17'
498 918JS	Remote Cable Assy. 18'
498 919JS	Remote Cable Assy. 19'

498 806JS	Remote Cable Assy. 6'
498 807JS	Remote Cable Assy. 7'
498 808JS	Remote Cable Assy. 8'
498 809JS	Remote Cable Assy. 9'
498 810JS	Remote Cable Assy. 10'
498 811JS	Remote Cable Assy. 11'
498 812JS	Remote Cable Assy. 12'
498 813JS	Remote Cable Assy. 13'
498 814JS	Remote Cable Assy. 14'
498 815JS	Remote Cable Assy. 15'
498 816JS	Remote Cable Assy. 16'
498 817JS	Remote Cable Assy. 17'
498 818JS	Remote Cable Assy. 18'
498 819JS	Remote Cable Assy. 19'

Additional lengths available, custom made.

Order two cables per motor.

Type 33-S cables with flexible wire guides are not interchangeable with Type S cables with rigid wire guides.

To determine correct cable length, measure distance from point Oliver Control is to be mounted aft, (towards the motor) along the side of the boat to the transom and around the corner from the side to the center of the motor location. To this measurement, add one (1) foot for the shorter cable and two (2) feet for the longer cable.

INTERCHANGEABLE PARTS:

B32015 Steering Bracket Assembly is interchangeable with #498 541JS or 498 452JS Steering Adapter Assembly.

A31028 Cable Terminal, Shift and Throttle is interchangeable with 498 760JS Connector Assembly-Shift and will replace 498 759JS Connector Throttle Assembly.

#498 756JS Extension Arm Kit consists of (1) B32112-2 Bracket-Throttle, (1) B32112-3 Bracket-Shift and Attaching Hardware.

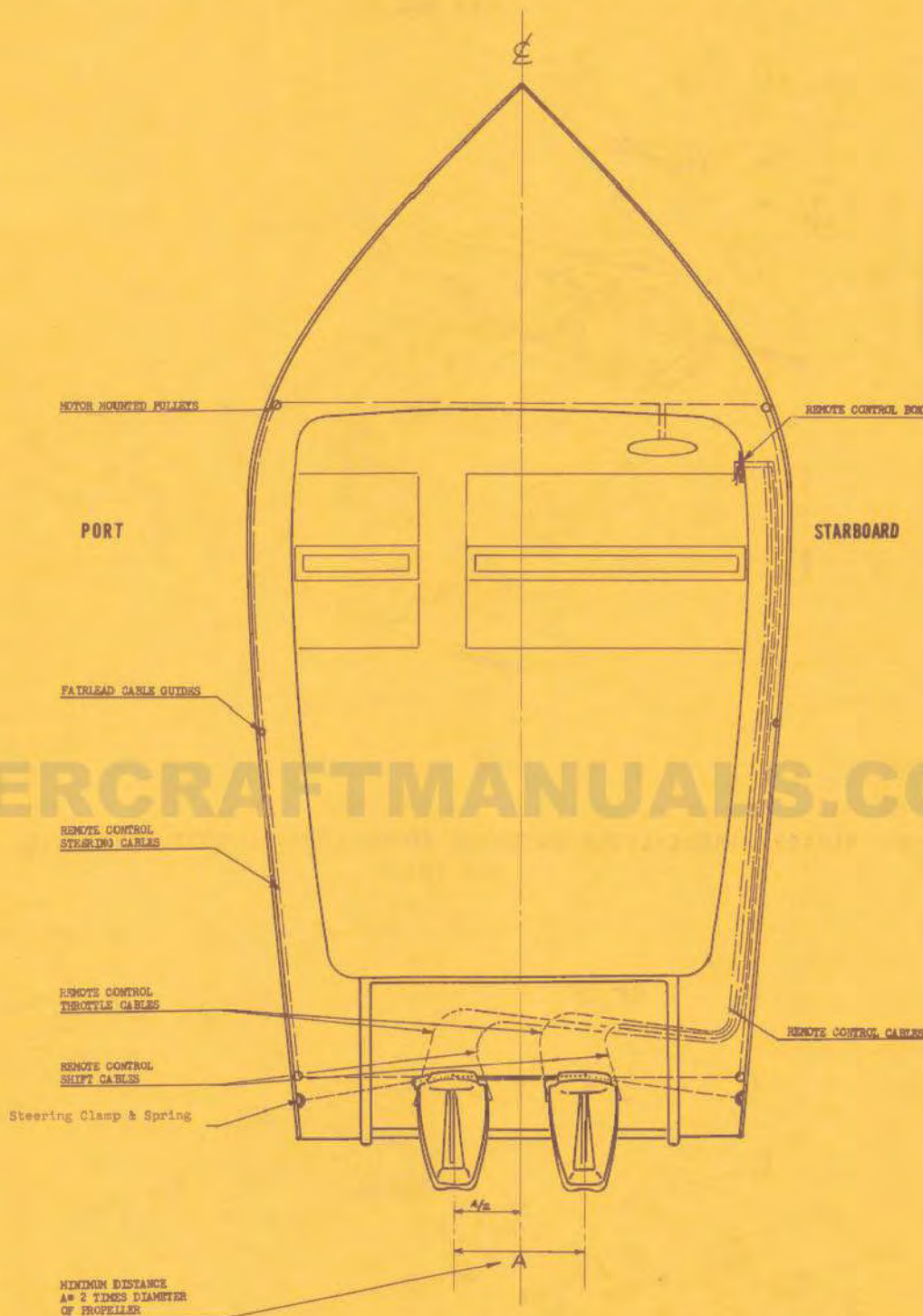

FIGURE 1

All directional references made to a boat and motor in nautical terms of "port" (left hand) and "starboard" (right hand), "fore" and "aft", "bow" and "stern". Illustration shows the use of these terms so just remember that when referring to any part of a boat or motor, it is as though you are sitting in the "stern" (rear) of the boat looking forward toward the "bow" (front).

OLIVER SINGLE-LEVER OUTBOARD MOTOR CONTROL MODEL-MBPS L.H.
498 902JS

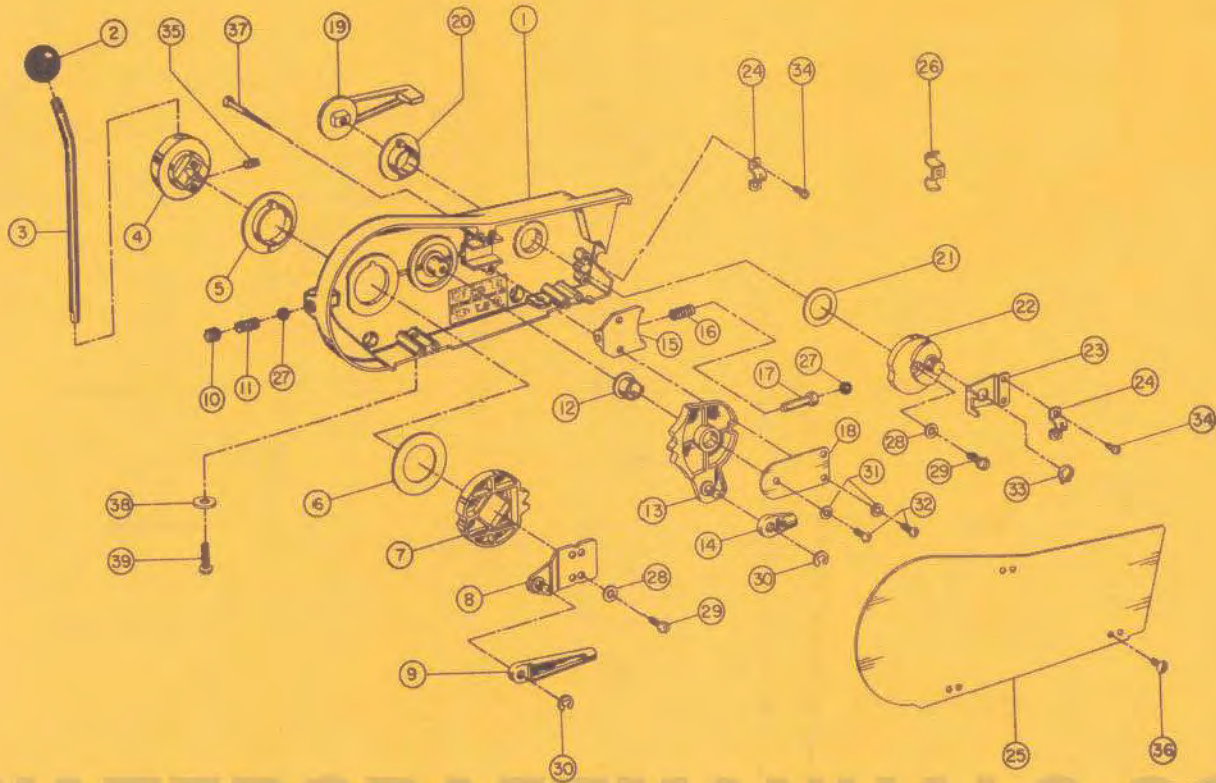

FIGURE 2

OLIVER SINGLE-LEVER OUTBOARD MOTOR CONTROL MODEL-MBSS R.H.
498 901JS

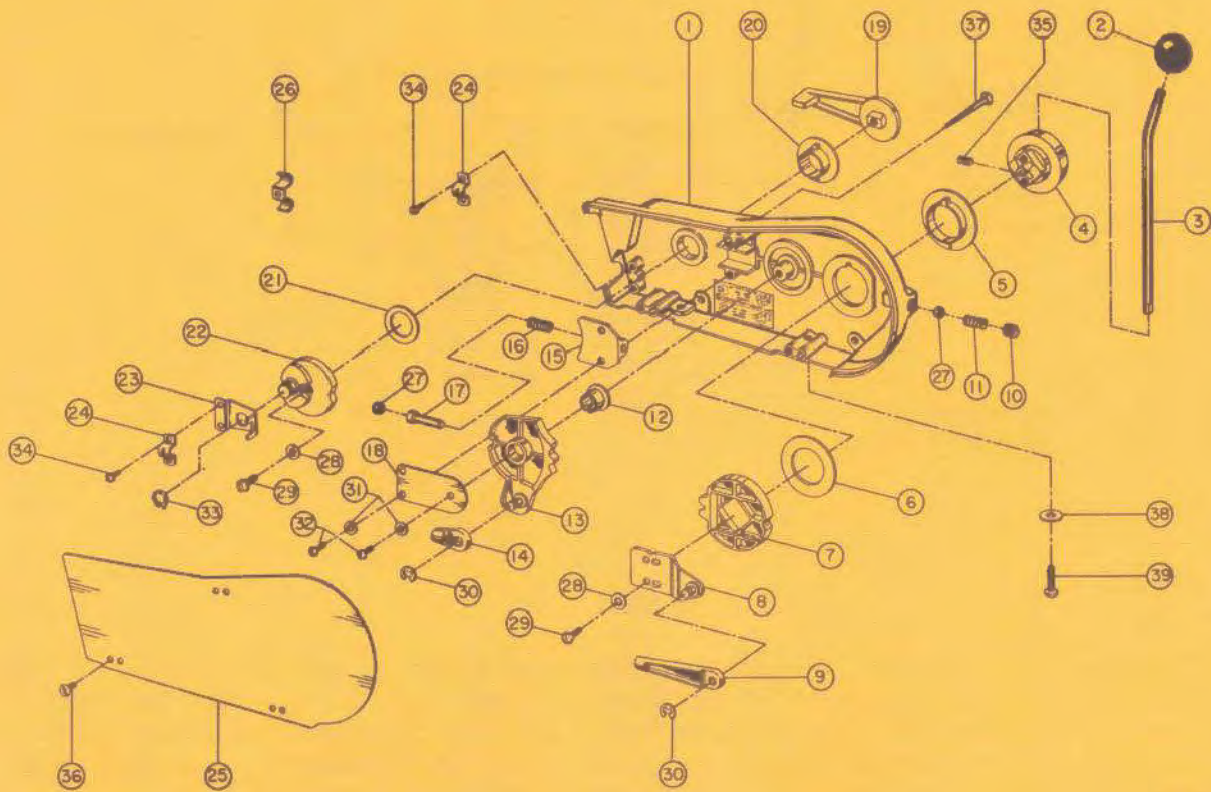

FIGURE 3

SINGLE LEVER REMOTE CONTROL MBPS AND MBSS
PARTS LIST

REF. NO.	QTY. REQ. L.H.	QTY. REQ. R.H.	PART NO.	DESCRIPTION
		1	498 910JS	Mono Lever Control Box Assembly-Starboard Includes Ref. 1 to 37 and #498 904JS Adaption Kit.
	1		498 902JS	Mono Lever Control Box Assembly-Port Includes Ref. 1 to 37 and #498 904JS Adaption Kit. NOTE: For twin motor control, order 1 each #498 901JS and 498 902JS Controls and Ref. #40, 3 each AD 021 Screws.
1		1	E32035	Housing - R.H.
1	1		E32036	Housing - L.H.
2	1	1	H32060-30	Ball, Knob
3	1	1	B32019	Lever, Control
4	1	1	B31985	Hub, Lever
5	1	1	A31997	Bearing
6	1	1	A32198	Washer, Waved
7	1	1	B31992	Gear, Drive
8	1	1	A32041	Arm Assembly
9	1	1	B31981	Fitting, Cable, Lg.
10	1	1	A32040	Plug, Detent
11	1	1	A31059	Spring, Detent
12	1	1	A32020	Bearing
13		1	B32045	Gear Assembly R.H.
13	1		B32043	Gear Assembly L.H.
14	2	2	A31980	Fitting, Cable
15	1	1	A31982	Retainer, Detent
16	1	1	A32021	Spring
17	1	1	A32016	Pin, Detent
18	1	1	A32002	Plate, Retainer
19	1	1	B32042	Lever, Neutral, Throttle
20	1	1	A31998	Bearing
21	1	1	A32018-1	Washer, Bowed
22	1	1	B31987	Crank
23	1	1	A32011	Bracket, Swivel
24	2	2	A32010	Clamp, Cable
25	1	1	D32044	Cover Plate
26	3	3	A31121	Support, Cable
27	2	2	COMM.	Ball, 3/8 Dia. Steel
28	3	3	920 154-1	Lockwasher, 1/4 Int. Tooth Stnls. Stl.
29	3	3	910 057-1	Screw, Fillister Hd. 1/4-20 x 5/8 Lg.
30	2	2	CF 007	Retaining Ring X5133-31W Type E
31	3	3	920 152-1	Lockwasher #10 Int. Tooth, Stnls. Stl.
32	3	3	909 019-1	Screw, Slotted, Rd. Hd. #10-24 x 1/2 Lg. Stnls. Stl.
33	1	1	CB 010	Retaining Ring 5100-50W Truarc
34	4	4	910 016-1	Screw, Fillister Hd. #10-24 x 3/8 Lg. Stnls. Stl.
35	1	1	909 865-1	Setscrew, Cup Pt. 5/16-18 x 1/2 Lg. Stnls. Stl.
36	3	3	AE 008	Screw, Mach. Slot Truss Hd. 10-24 x 3/8 S.S.
37	3	3	926 062-1	Screw, Wood, Slot, Oval Hd. 10 x 2-1/4 Lg. S.S.
38	2	2	920 007-1	Washer, Flat 1/4" (Obtain Locally)
39	2	2	909 059-1	Screw, Mach., Slot Rd. Hd. 1/4-20 x 1-1/4 Lg. (Obtain Locally)
40	3	3	AD 021	Screw, Mach., Slot, Oval Hd. #10-24 x 1-3/4 Lg. Stnls. Stl. (Not Shown)
41	3	3	926 175-1	Screw, Wood, Slot, Truss Hd. 12 x 3/4 Lg. (Not Shown) Obtain Locally

INSTALLATION

The material required to make a OLIVER SINGLE-LEVER control installation for one motor is:

1. Control Head. Right Hand or left hand units available. Right and left units combine to make a twin unit.
2. Two Type 33S Push-Pull Cables.
3. Motor Adaption Kit.

Typical installations are shown in Fig. 4.

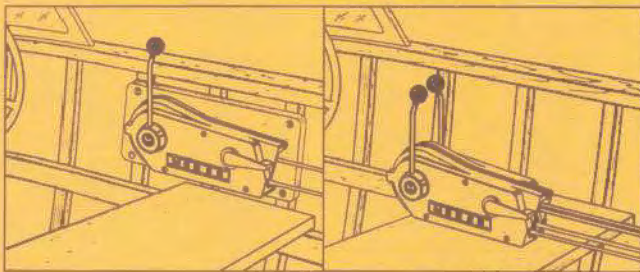

FIGURE 4

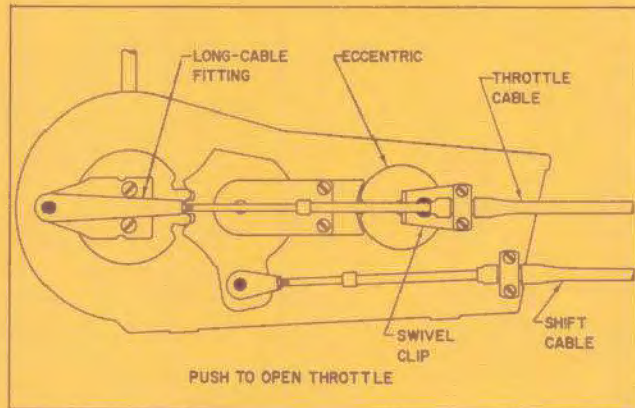

FIGURE 5

The Control, right hand, left hand or twin is mounted either by screws into a side mounting board or machine screws up through the seat board. Twin or Single (R.H. or L.H.) models are seat mounted by machine screws and washer. (40) (41)

Twin models are mounted on a block or side mounting board with three wood screws. (42) Mount the outer half to the boat then attach the inner half with machine screws. (38)

Right hand or left hand models are mounted to the block or side mounting board with three 2-1/4 inch long, oval head wood screws. (39)

NOTE - When two units are used together as a twin control, the back plates (27) are discarded.

The SINGLE-LEVER (4) can be turned in its mounting hub (5) to offset the knob to either side for maximum clearance. Twin installations have the SINGLE-LEVER knobs (3) offset toward each other for one hand operation.

When choosing the Control Head location for your boat provide clearance for movement of the SINGLE-LEVER and a clear path for the push-pull cables from the Control Head to the motor. Connect and check out the Control Head, Push-Pull Cables and Motor Adaption Kit before finally fastening the Control Head to your boat.

CONNECTING THROTTLE AND SHIFT CABLES

Outboard Motors have either push to open or pull to open throttles and Oliver SINGLE-LEVER Controls are designed to operate either kind. The Oliver ML SINGLE-LEVER Control is assembled at the factory for pull to open motor throttle such as:

Mercury, Scott and Oliver 35 HP.

For push to open motors such as: Evinrude, Johnson, Gale Products, West Bend and Oliver 16 H.P. the control throttle lever (9) will have to be reversed (See Fig. 6) and the long cable end fitting (16) used. The neutral throttle eccentric (24) must also be reversed. To reverse the neutral throttle eccentric, move the neutral throttle lever (21) forward, out of its detent. Unscrew the 1/4-20 machine screw (31) under the swivel clip (25) until the neutral throttle lever is free to return to its back position.

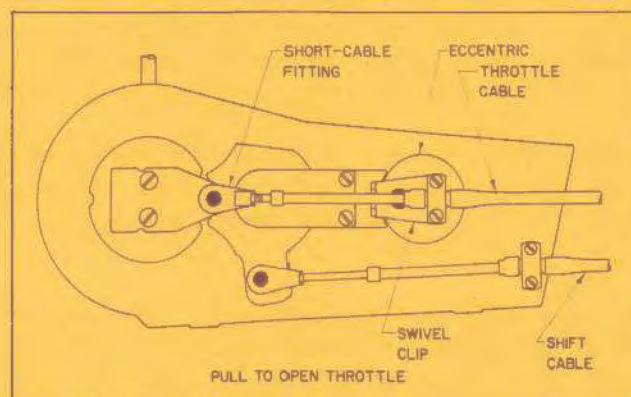

FIGURE 6

WARNING

Hold the eccentric against the housing (2) to retain detent ball and spring.

Turn the eccentric to its other detent and tighten the machine screw, in this position. Be sure the screw is tight, connect shift cable as shown in Fig. 5. Mount the control in a position that will allow at least 3 feet of free, straight cable run from the rear of the unit. Also provide enough cable length for the motor movement during steering and for motor tilt up.

Neutral throttle in the ML Control is obtained by movement of the casing of the throttle cable and any restriction of the cable for the first 3 feet back of the control head will interfere with this action.

Minimum recommended cable bend radius is 8 inches, smaller bends will tend to reduce cable efficiency. Avoid tight bends that might kink the inner core wire.

MOTOR CONNECTIONS

A motor adaption kit consisting of cable terminals and mounting brackets to connect the cables to the motor is furnished with the control head as ordered. Kits are available for most makes and models of outboard motors.

Instructions for the installation of the kit and connection of the cables is included with the kit for the specified motor.

ADJUSTMENT OF THE THROTTLE AND SHIFT ON MOTOR

Be sure the motor is adjusted so that it idles properly and at about 900 RPM. A single lever control will not work satisfactorily with a motor that stalls out at idling speed. Excessively high idle speeds, (over 1,000 RPM) may cause some motors to hang in gear and shift out hard to neutral. Make sure the motor throttle lever works freely. Do this by lubrication and eliminating binding, interferences, etc. Make sure the motor shift lever works freely. Do this by lubrication and freeing up the linkage. Be sure the detents in the motor are properly installed, adjusted and lubricated. They should correspond with the lever positions in the control head.

WARNING

Do not attempt to force the shift lever when the motor is not running. It might cause damage to the Control Head, Push-Pull Cables or motor.

OPERATION

When operating the motor from the remote control, shifting should be done quickly, so as to snap the shift into forward or reverse. Except for emergency do not shift from an advance forward speed into reverse. Come back to forward idle position until the boat has lost most of its head-way before reversing.

The Oliver Model ML SINGLE-LEVER Control is designed especially for the remote control of outboard motors and has the same basic Morse intermittent gear action that has been used for years on all types of commercial, military, and pleasure craft.

It provides safe, instinctive control of the boat. The boat always moves with the control lever, ahead as the lever is moved forward and backwards as the lever is moved back. Because of this, inexperienced persons can operate the boat safely and surely with a minimum instruction time.

It automatically idles the throttle before shifting yet provides throttle in neutral for starting and warm-up.

The neutral throttle cannot be advanced unless the SINGLE-LEVER is in neutral. The SINGLE-LEVER cannot be moved from neutral unless the neutral throttle lever is in the (down) idle position.

LUBRICATION AND MAINTENANCE

The Control Head is constructed throughout of aluminum, stainless steel and nylon and requires approximately the same degree of care as your outboard motor particularly for service in salt water.

For maximum corrosion protection, all metallic mating surfaces, screws, etc. should be bedded in with water proof grease when assembled.

Metallic parts, screw heads, cable ends, etc. should be wiped with oil or light grease regularly.

When laying up the boat brush all metal parts of the control, cable clips and cable ends with motor oil or light grease.

Oliver Controls and equipment covered by United States and Foreign Patents, issued and pending.

INSTALLATION INSTRUCTIONS

MOTOR ADAPTION KIT P/N 498 904JS FOR OLIVER 35 H.P. MOTOR
USE WITH OLIVER OUTBOARD MOTOR CONTROLS
MODEL MBPS --- MODEL MBSS --- MODEL MBUT

MOTOR ADAPTION KIT

For Oliver 35 HP Parts List

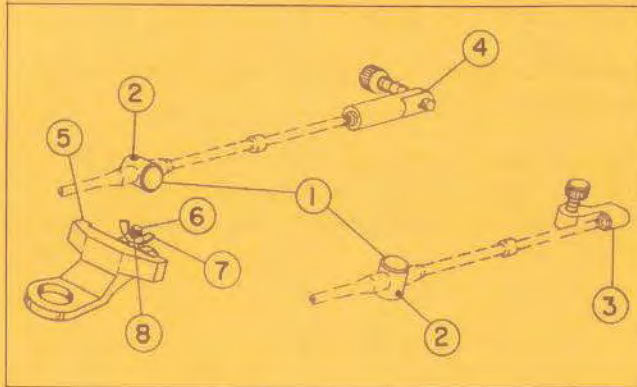

FIGURE 7

Item No.	Description	No. Reqd.	Part No.
1	Trunnion Cable	2	A31341
2	GROOVE PIN TYPE 2, 1/8" Dia. x 1/2 Long	2	DJ 005
3	Cable Terminal, Throttle	1	A31424
4	Cable Terminal, Shift	1	A31028
5	Steering Bracket	1	D31977
6	BOLT	1	A32014
7	WING NUT 5/16-18	1	EF 001
8	Cotter Pin 3/32 Dia. x 1/2 Long	1	DB 002

PREPARATION OF MOTOR

The motor should be checked out before beginning the kit installation. Inspect the following points:

1. Motor Idle speed-set the idle speed correctly.
2. Throttle Linkage-free up and lubricate.
3. Shift linkage-free up and lubricate.
4. Shift detents-make as light as possible.
5. Lubrication-Lubricate all moving parts as recommended.

WARNING

Do not force the motor shift lever when the motor is not running. When shifting remember to rotate the propeller by hand to insure full engagement of the clutch.

CORROSION

It is good practice to coat mating surfaces of brackets and motor, screws, cable ends, etc. with water-proof grease. This protects them from corrosion which is especially bad in salt water operation.

CABLE TRUNNION ASSEMBLY

Assemble a cable trunnion (1) on the end of both throttle and shift cables.

Do this by slipping trunnion (1) on cable until hole in trunnion lines up with groove in cable. Press groove pin (2) in trunnion and groove in cable.

SHIFT CABLE CONNECTION

Put the SINGLE-LEVER in neutral detent. Also set the motor shift lever in neutral.

Turn the shift cable terminal (4) onto the shift cable.

Put cable trunnion (1) in socket on motor. Latch in place.

Turn the cable terminal as required to make its pin line up with the hole in the motor shift lever.

See final check out for further adjustment.

THROTTLE CABLE CONNECTION

This is a pull open throttle.

Disconnect the shift cable from the motor shift lever and move the motor shift lever to forward. See the WARNING about shifting the motor when it's not running.

Set the SINGLE-LEVER at neutral and the motor throttle lever at the idle stop.

Turn the throttle cable terminal onto the throttle cable. Place the throttle cable trunnion in motor socket and latch in place.

Turn the throttle cable terminal as required to make its pin line up with the hole in the motor throttle lever. In the neutral position, as the motor and control head are, the cable terminal should pull the motor throttle lever snugly against the idle stop.

FINAL CHECK OUT

These things MUST BE RIGHT for good operation of your Oliver SINGLE-LEVER Control.

1. Check the shift cable travel.

See the WARNING about NOT forcing the shift lever.

Disconnect cable from motor shift lever.

Put SINGLE-LEVER in NEUTRAL. Put motor shift lever in neutral.

Turn the cable terminal until its pin lines up with the hole in the motor shift lever.

2. Check motor throttle lever travel.

Move SINGLE-LEVER to FORWARD. NOTE whether motor shift is completed before throttle starts to open. If not, adjust throttle cable terminal to pull throttle lever snugly against idle stop.

3. Tighten all hardware including cable end locknuts.

4. Attach cables being sure all clips are closed.

5. Lubricate all moving parts with waterproof grease.

6. The final proof of correct SINGLE-LEVER control installation is obtained during a test run on the water. The SINGLE-LEVER works easily and smoothly when checked out correctly.

7. If you should change motors be sure to have the right Motor Adaption Kit, AND go thru this Final Check Out.

OPERATION

Shift firmly from neutral to either forward or reverse. This engages the shift clutch quickly and protects it from damage.

When shifting back to neutral allow motor speed to decrease to idle or thereabouts before shifting. Do this by returning the SINGLE-LEVER to the position between the end of shift and start of throttle range. Pause there a moment until Motor RPM drops and shift firmly to neutral.

MOTOR STEERING BRACKET

The bracket (5) is furnished to provide clearance between steering cables and motor control Push-Pull cables.

Attach bracket (5) to motor securely using bolt (6), wingnut (7), and cotter pin (8).

OLIVER TWO LEVER OUTBOARD MOTOR CONTROL P/N 498 900JS
PARTS LIST

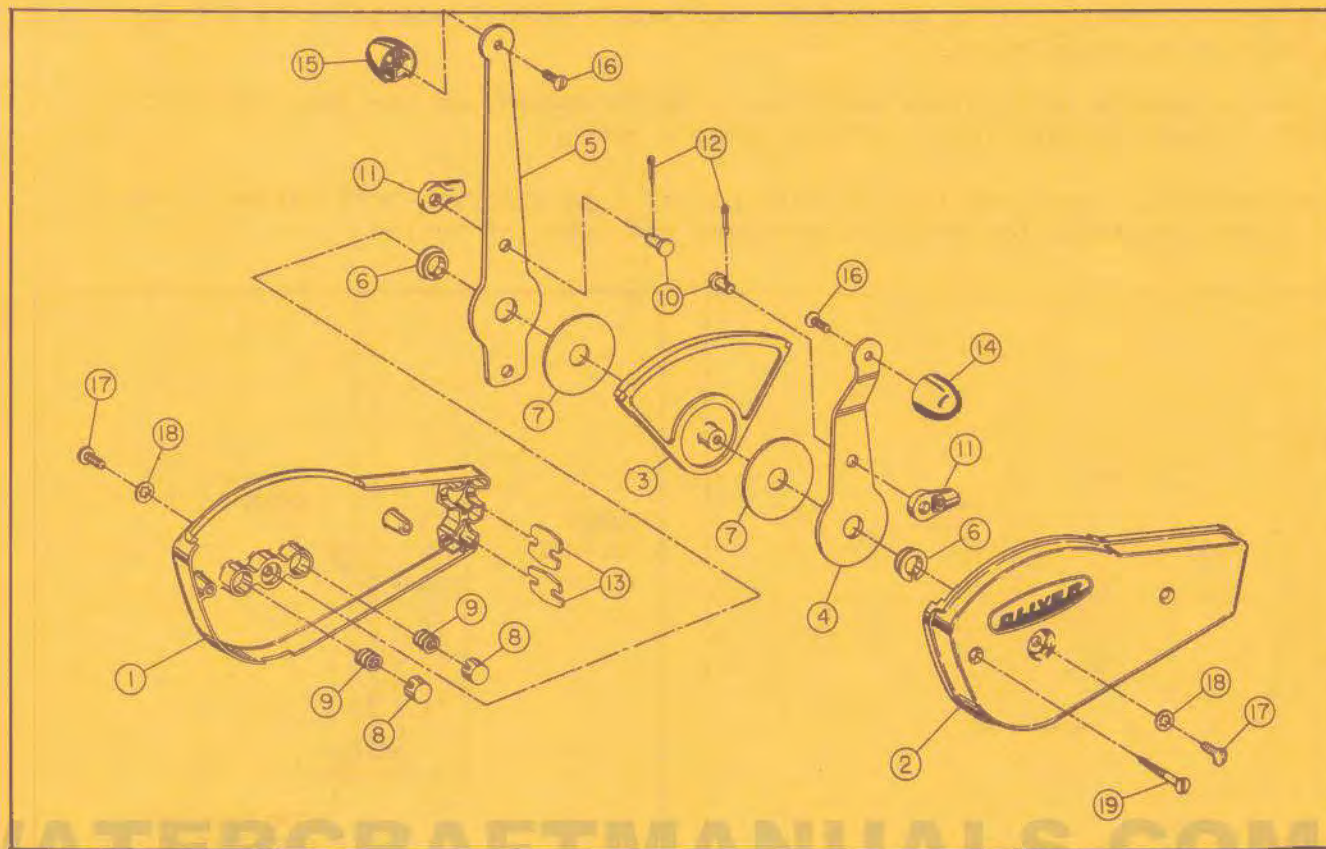

FIGURE 8

REF. NO.	PART NUMBER	NO. REQ'D	DESCRIPTION
	498 900JS		Two Lever Control Box Assy. (Included Ref. #1 to 19 & 21)
1	E31986	1	HOUSING R.H.
2	E31983	1	HOUSING L.H.
3	B31813	1	Separator Segment
4	A31994	1	SHIFT LEVER - Short, Offset
5	B31989	1	THROTTLE LEVER - Long, Straight
6	E32007-20	2	Bearing
7	A31984	2	Brake Disc
8	A32005	2	Brake Shoe
9	A32006	2	Brake Spring
10	A32023	2	Pin, Lever
11	A31980	2	CABLE END FITTING
12	932 007-1	2	Cotter Pin 3/32 Dia. x 1/2 Lg. Stnls Stl.
13	A31983	2	Cable Casing Clip
14	A31812-1	1	Knob - Shift, Black
15	A31812-2	1	Knob - Throttle, Red
16	910 191-1	2	Screw - Truss Hd. Mach. #10-24 x 5/8 Lg. Stnls. Stl.
17	909 054-1	2	Screw - Rd. Hd. Mach. #1/4-20 x 5/8 Lg. Stnls. Stl.
18	920 154-1	2	Lockwasher - Int. Tooth #1/4 Stnls. Stl.
19	926 074-1	2	Wood Screw - Flat Hd. #12 x 2-1/2 Lg. Stnls. Stl.
20	COMM.	2	Wood Screw - Flat Hd. #12 x 4-1/4 Stnls. Stl. For Twin Mtg. - Obtain locally
21	498 423J	2	Name Plate

NOTE: Motor Adaption Kits are not included with the #498 900JS Control Assy, Order #498 903JS Motor Adaption Kit for 16 HP Oliver. Order #498 904JS Motor Adaption Kit for 35 HP Oliver.

INSTALLATION INSTRUCTIONS

The Oliver Model TL is a universal, two lever control, adaptable to all makes and models of outboard motors.

Interchangeable parts allow controls to be assembled, on the job, for right or left, single or twin installations, Fig. 9 and 10.

The control is designed for use with Oliver Type 33S Push-Pull Cables. Adaptor kits are available for using other makes and types of cables.

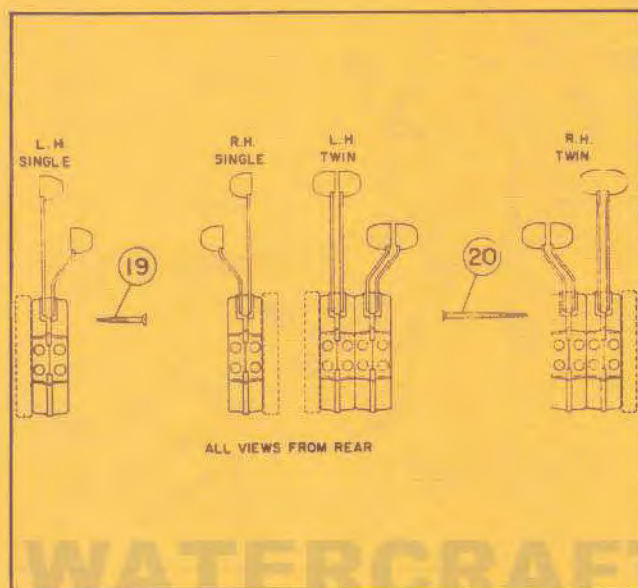

FIGURE 9

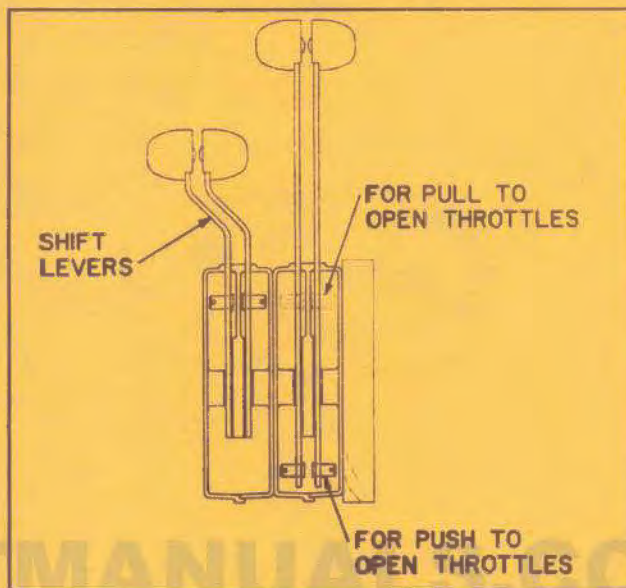

FIGURE 10

DESCRIPTION OF CONTROL HEAD

The control head has two mating case halves, Item (1) and (2) of Figure 8 with a separator segment (3), held between them.

The shift lever (4) and throttle lever (5), with nylon bearings (6), pivot on the shaft hubs of the segment.

Brake discs (7) are on either side of the segment. These discs act as a guide for the shift lever and as a brake face for the throttle lever. Do not remove the discs even when brake is not used.

Each case half has two pockets to receive the nylon brake shoes (8) and brake springs (9). The brake shoes and springs are used only against the throttle lever. Leave the pockets empty adjacent to the shift lever.

The shift lever (4) has a removable pin (10) for use with twin assemblies as in Fig. 10 where both shift levers are assembled in one case.

The throttle lever (5) has two holes for its pin. Use the upper hole for "pull-to-open" throttles and the lower hole for "push-to-open" throttles. Assemble pins in levers so that pins point outwards, away from the separator segment (3).

Knobs may be attached to either side of levers. Use black on shift and red on throttle.

Cable end fittings (11), are tapped for 10/32 cable ends and are retained on the lever pins by cotter pins (12).

Clips (13), fit Oliver Type 33-S Cable Casing. (See your dealer for adaptors for other makes and types of cables.) The clips allow cable connections to either side, top or bottom of the control. Replace unused clip in case before assembly.

Assemble one half case and parts at a time with the separator segment (3), using screw (17) and lockwasher (18).

DESCRIPTION OF PUSH-PULL CABLES

Minimum recommended bend radius is 8 inches, smaller bends will tend to reduce cable efficiency. Avoid tight bends that might kink the inner core wire.

Cables connect to the TL Control Head as shown in Figure 11.

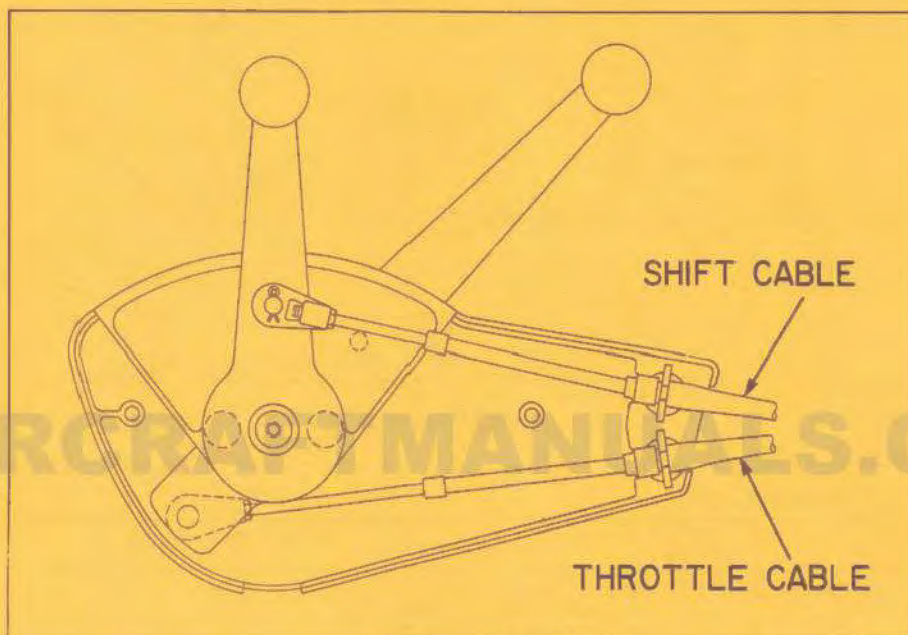

FIGURE 11

MOTOR CONNECTION KITS

Cable terminals and mounting brackets to connect the cables to the motor are furnished with the control head as ordered and are available for most makes and models of motors.

MAINTENANCE

The Control head is constructed throughout of aluminum, stainless steel and nylon and requires approximately the same degree of care as your outboard motor particularly for service in salt water.

For maximum corrosion protection, all metallic mating surface, screws, etc. should be bedded in with grease when assembled.

Metallic parts, screw heads, cable ends, etc., should be wiped with oil or light grease regularly.

When laying up the boat, brush all metal parts of the control, cable clips and cable ends with motor oil or light grease.

Oliver Controls and equipment covered by United States Foreign Patents, issued and pending.

INSTALLATION INSTRUCTIONS

MOTOR ADAPTION KIT P/N 498 903JS FOR OLIVER 16 H.P. MOTOR
USE WITH OLIVER OUTBOARD MOTOR CONTROLS
MODEL MKUT --- MODEL HKUT --- MODEL HKDT

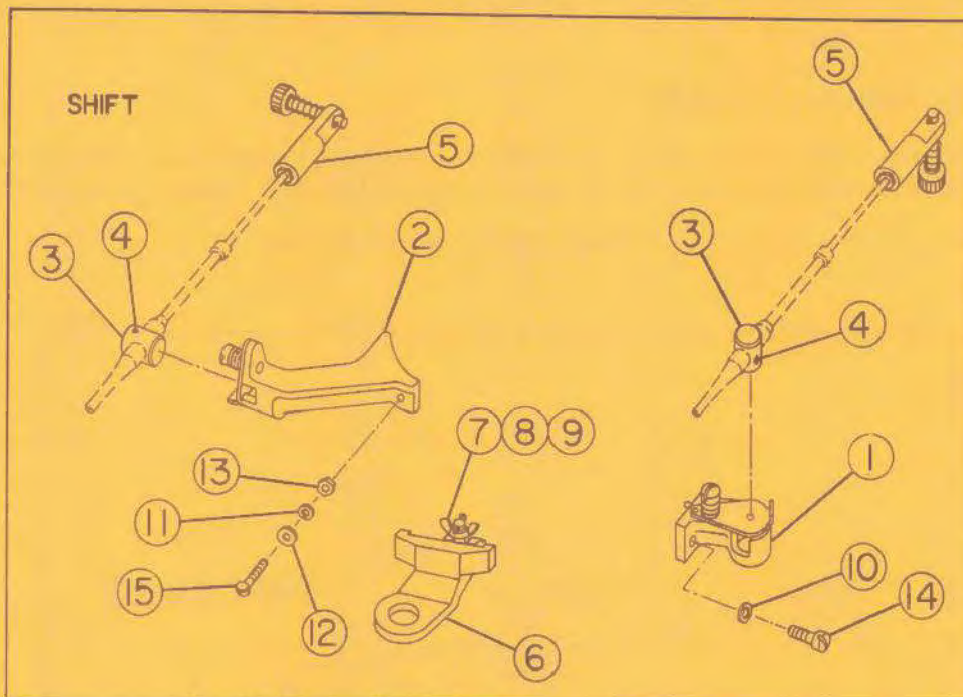

FIGURE 12

MOTOR ADAPTION KIT

For Oliver 16 HP Parts List

ITEM NO.	PART NUMBER	NO. REQD.	DESCRIPTION
1	B32112-2	1	BRACKET, THROTTLE
2	B32112-3	1	BRACKET, SHIFT
3	A31341	2	Trunnion, Cable
4	DJ 005	2	Groove Pin-Type 2, 1/8 Dia. x 1/2 Long
5	A31028	2	Cable Terminal, Shift and Throttle
6	D31977	1	STEERING BRACKET
7	A32014	1	Bolt
8	EF 001	1	Wing Nut 5/16-18
9	DB 002	1	Cotter Pin 3/32 Dia x 1/2 Long
10	920 081-1	1	Washer, 1/4 Split Lock
11	920 079-1	2	Washer, #10 Split Lock
12	920 005-1	2	Washer, #10 Flat
13	915 538-1	2	Nut, Hex #10-24
14	910 057-1	1	Screw, Fil. Hd. 1/4-20 x 5/8 Long
15	909 022-1	2	Screw, Rd. Hd. Slotted #10-24 x 3/4 Long

PREPARATION OF MOTOR

The motor should be checked out and adjusted before beginning the kit installation. Inspect the following points:

1. Motor idle speed - set the idle speed correctly.
2. Throttle linkage - free up and lubricate.
3. Shift linkage - free up and lubricate.
4. Shift detents - make as light as possible.
5. Lubrication - lubricate all moving parts as recommended.

WARNING

Do not force the motor shift lever when the motor is not running. When shifting remember to turn the propeller by hand to insure full engagement of the clutch.

CORROSION

It is good practice to coat mating surfaces of brackets and motor, screws, cable ends, etc. with waterproof grease. This protects them from corrosion which is especially bad in salt water operation.

BRACKET INSTALLATION

Attach throttle bracket (1) to motor housing. Use mounting pad at left, front corner of motor. Use screw (14) and lockwasher (10).

Attach shift bracket (2) to motor housing. Use screw holes in right, front corner of motor. Use screws (15), flat washers (12), lockwashers (11), and nuts (13).

CABLE TRUNNION ASSEMBLY

Assemble a cable trunnion (3) on both throttle and shift cables.

Do this by slipping trunnion (3) on cable until hole in trunnion lines up with groove in cable. Press groove pin (4) in trunnion and groove in cable.

SHIFT CABLE CONNECTION

Put the SINGLE-LEVER in neutral detent. Also set the motor shift lever in neutral.

Turn the shift cable terminal (5) onto the shift cable .

Put cable trunnion (3) in socket of shift bracket (2). Latch in place.

Turn the cable terminal (5) as required to make its pin line up with the hole in the motor shift lever.

See final check out for further adjustment.

THROTTLE CABLE CONNECTION

This is a push to open throttle. Disconnect the shift cable from the motor shift lever and move the motor shift lever to forward. See the WARNING about shifting the motor when it's not running.

Set the SINGLE-LEVER at neutral and the motor throttle lever at the idle stop.

Turn the throttle cable terminal onto the throttle cable. Place the throttle cable trunnion in socket and latch in place.

Turn the throttle cable terminal as required to make its pin line up with the hole in the motor throttle lever.

In the neutral position, as the motor and control head are, the cable terminal should pull the motor throttle lever snugly against the idle stop.

FINAL CHECK OUT

These things MUST BE RIGHT for good operation of your Oliver SINGLE-LEVER control.

1. Check the shift cable travel.

See the WARNING about NOT forcing the shift lever.

Disconnect cable from motor shift lever.

Put SINGLE-LEVER in neutral. Put motor shift lever in neutral. Turn shift cable terminal until its pin lines up with the hole in the motor shift lever.

2. Check motor throttle lever travel.

Move SINGLE-LEVER to FORWARD. Note whether motor shift is completed before throttle starts to open. If not, adjust throttle cable terminal to pull motor throttle lever snugly against idle stop.

3. Tighten all hardware including cable end locknuts.

4. Attach cables being sure all clips are closed.

5. Lubricate all moving parts with waterproof grease.

6. The final proof of correct SINGLE-LEVER control installation is obtained during a test run on the water. The SINGLE-LEVER works easily and smoothly when checked out correctly.

7. If you should change motors be sure to have the right Motor Adaption Kit, and go thru this Final Check Out.

OPERATION

Shift firmly from neutral to either forward or reverse. This engages the shift clutch quickly and protects it from damage.

When shifting back to neutral allow motor speed to decrease to idle or thereabouts before shifting. Do this by returning the SINGLE-LEVER to the position between the end of shift and start of throttle range. Pause there a moment until Motor RPM drops and shift firmly to neutral.

MOTOR STEERING BRACKET

This bracket (6) is furnished to provide clearance between steering cables and motor control Push-Pull cables.

Attach bracket (6) with bolt (7) wing nut (8) and cotter pin (9).

This is a supplement to bulletin SM-1-56 Remote Control Installation. Requests have been received from the field about mounting dual single lever controls on the port (left) side of a boat. The list of parts and procedure for installation is as follows:

PARTS REQUIRED:

1	#498 901	Single Lever Box R.H.
1	498 902	Single Lever Box L.H.
3	10-24 x 1-3/4"	Flat Head Machine Screw
3	12 x 3/4"	Slotted Head Wood Screws
3	12 x 1-1/2"	Slotted Head Wood-Port Side Only

INSTALLATION:

1. Remove back plates from both #498 901 and 902 Control Boxes and assemble together with (3) #10-20 x 1-3/4" Flat Head Machine Screws.
2. The Outer portion of assembly does not have (3) side mounting bosses as does the inner portion for port side of a boat so it is necessary to drill (3) 1/4" dia. holes in the outer portion. Use the (3) 1/4" dia. hole bosses on inner portion as a guide and mark through with a pencil to the left side.
3. Disassemble boxes by removing the (3) #10-24 screws and note (3) drill locations already cast into left hand box portion. Drill these three location with 1/4" dia. drill.
4. Make spacers for the outer unit as bosses are not cast into this section and 3/4" clearance is needed to properly operate single lever handles. As a suggestion use a strip of wood 3/4 x 1-1/4 x 10" and place along lower edge (outboard side) between inner portion and boat mounting block. This will pick up the lower two holes. Make one piece 1" square for top hole and drill out in center with 1/4" drill. Drill through lower block with the two holes located using 1/4" drill.
5. Using (3) #12 x 1-1/4 slotted head wood screws, attach outer portion of assembly to mounting block on boat using spacer at (3) locations, previously mentioned.
6. Having outer portion securely fastened to boat, attach inner portion with (3) #10-24 x 1-3/4" machine screw flat head.

Service Department

SERVICE



BULLETIN

OLIVER OUTBOARD MOTORS

DIVISION OF OLIVER CORPORATION

108 SOUTH McCAMLY STREET • BATTLE CREEK, MICHIGAN

SM-1-39
August

TO: All Oliver Outboard Motor Distributors and Dealers

SUBJECT: Instructions for Assembling and Mounting the Throttle and Shift Remote Control Box to the Oliver 35 HP Olympus Motor.

The control box is complete and requires only the fastening of the remote control cables to the control box and shift and throttle connector to the cables at the motor end. The cables are not part of the control box. The remote control cables must be purchased separately. Purchase two cables of desired length for each motor.

Measure from the forward end of the remote control box location aft around the outside of the boat to the center of the nearest motor. This is the length of the shortest cable required, add one foot, two feet and three feet for the other cables. For a single engine add one foot for the longer cable.

The Oliver Dual Remote Control, Part #498 744-JS is assembled for right hand mounting. Part #498 745JS is assembled for left hand mounting.

The Oliver Single Remote Control, Part #498 737-JS is assembled for right hand mounting. Reference to right or left hand mounting is the hand which the operator will use to operate the controls. The control can be mounted to the right or the left of the operator.

The remote controls can be changed from right to left hand mounting by removing the oval head screw, Ref. #14, and opening the control box. Loosen the shoulder screws, Ref. #19. Remove the arm assemblies, Ref. #3 and #4 from the control box and drive out the groove pins, Ref. #28. Interchange the shift and throttle control handles, Ref. #6 and #26. Turn the handles a half turn and reassemble, using the groove pin, Ref. #28. Remove screw, Ref. #16 and spring, Ref. #15 and install on the opposite arm which will be the new throttle control. Reassemble the arm assemblies to the control box and fasten with the shoulder screws, Ref. #19. Caution:- Support the box half in a vise or by some other means.

Compress the index spring, Ref. #15, before starting the shoulder screw, Ref. #19. This will help prevent cross threading the screw into the box. The box is aluminum and the threads are easily damaged. Torque to 60 inch pounds. Do not over-tighten. Close the box and fasten together, using the oval head screw , Ref. #14.

To attach the remote control cables to the control box, remove screw, Ref. #14 and open the control box. Move the throttle handle, Ref. #6 to the right as shown in drawing. Turn anchor pin, Ref. #5 to line up with the cable. Note:- This anchor pin, Ref. #5, should turn freely. If this pin binds, remove and ream the hole or sand paper the anchor pin. Lubricate with a good waterproof grease before assembly. Pick up the end of the longer control cable without the jam nut. Pull out the inner core 4-1/2 inches. Hold the box in the left hand and the cable in the right hand. Start the threaded end of the inner core into the anchor pin, Ref. #5 by turning the cable. After the cable is started, hold the box in a vertical position and turn the entire box. If the inner core turns, use smooth jawed pliers to hold the inner core to prevent turning. Screw the inner core all the way through the anchor pin, Ref. #5, but do not let end of the inner core protrude. The end of the core must be flush with the anchor pin for proper operation. The cable assembly has a wire guide approximately 5 inches long, with a barrel shaped trunion installed on it, screw the barrel trunion to within 3 inches from the end of the wire guide measuring from the unthreaded end. Move the throttle to the left as shown on drawing. This is the forward end of the box. Assemble the barrel trunion into the recess milled into the box to receive the trunion.

Follow the same procedure for the shift as outlined for the throttle except use the shorter cable for the shift. For left hand mounting the long and short cables will be interchanged.

Close the box and fasten, using oval head screw, Ref. #14.

Screw connector hitch assembly, Ref. #8 on the throttle cable and tighten the jam nut. Screw connector hitch assembly, Ref. #9 on the shift cable and tighten the jam nut. Note: Pin, Ref. #10 is assembled on flat side of connector for shift control. Fasten the connector pins, Ref. #12 to the throttle and shift levers on the motor and adjust the barrel trunion for proper operation. Adjust the throttle so that the throttle handle will be 1/4 to 1/2 inches from the forward end of the control box when the throttle is fully advanced, Adjust the shift handle so that the

handle will be in the center of the control box with shift in neutral position. At this adjustment the remote shift handle should not hit either end of the control box when motor is shifted to forward or reverse.

Dual controls are assembled with the same parts with the exception of the dual throttle handle, Part #498 453-J and Dual shift handle Part #498 454-J and two (2) screws round head, part #909 019-1.

To mount the dual remote controls to the boat using the wood screws provided, remove the screw, Ref. #14 from the shift side of the box. Open the control box and remove the two small round headed screws. Fasten the control box part with the two throttle handles to the boat using the two mounting screws provided, Ref. #13. Attach the shift handle part of the box to the throttle box using the round headed screws. Install the box cover using screw, Ref. #14.

If the dual controls have been changed from right to left or visa-versa, it will be necessary to assemble the control box completely and obtain longer screws, 4-1/2 to 5 inches long, from a local hardware store, to fasten the control box to the boat.

WATERCRAFTMANUALS.COM

hbd

C-3955-A58

PARTS LIST

35 HP SINGLE REMOTE CONTROL

REF. NO.	ASSEMBLY PART NO.	NO. REQ.	PART NUMBER AND DESCRIPTION	MFG. PART NO.
	498 737JS		Remote Control-Single-35 HP (Incl. Ref. #1-29)	
1		1	498 434J Box	58-P-200
2		1	498 435J Cover	58-P-202
3		1	498 437J Arm-Throttle	56-P-167
4		1	498 436J Arm-Shift	56-P-168
5		2	498 442J Pin-Anchor	56-F-6
6		1	498 440J Handle-Throttle	58-P-129
7		1	498 445J Ball-Throttle-Red	25-R
	498 759JS	1	Connector Hitch Assy. Throttle (Incl. Ref. #8, 10, 11 & 12)	
8		1	498 757J Connector Hitch Throttle	57-SLP-344
	498 760JS	1	Connector Hitch Assy. Shift (Incl. Ref. #9, 10, 11 & 12)	
9		1	498 733J Connector Hitch Shift	57-SLP-344
10		2	932 796-1 Pin-Groove 3/32 x 3/8 Lg. Type F	
11		2	460 191J Spring 3/8	56-P-126
12		2	498 446J Pin, Connector-Throttle	55-P-120
13		2	926 064-1 Screw, Wood #10 x 3"	
14		1	AD 021 Screw, Oval Hd. #10-24 x 1-3/4 Lg.	
15		1	498 438J Spring, Index	58-P-109
16		1	909 132-1 Screw, Rd. Hd. #10-32 x 1/4	
17		4	498 448J Washer, Fiber	
18		2	498 447J Washer, Wave (Spring Tension)	
19		2	498 443J Screw Shoulder	56-F4
20		1	498 439J Separator	58-P-207
21		2	AE 007 Screw Truss Hd. #10-24 x 1/4	
	498 452JS	1	Steering Adapter Assy. (Incl. Ref. #22, 23, 24 & 25)	
Same As	498 541JS			
22		1	EF 001 Nut, Wing 5/16-18	
23		1	498 451J Block Adapter	55-SC-10-0
24		1	498 450J Bar, Steering	55-SC-11-0
25		1	498 449J Screw, Shoulder	55-SC-12-0
26		1	498 441J Handle, Shift	57-P-130-C
27		1	498 444J Ball, Shift (Black)	25-B
28		2	932 814 Pin, Groove 1/8 x 5/8 Type F	
29		2	498 423 Decal Metal (Name Plate)	
	498 744JS		Dual Remote Control R.H.	
	498 745JS		Dual Remote Control L.H.	
			Dual Remote Controls use the same parts for both R.H. and L.H. Dual Controls incl. double quantities Ref. 1-29 with the exception of 6 and 26. Also following 3 items.	
	6	1	498 453J Handle Throttle-Dual	
	26	1	498 454J Handle-Shift-Dual	
		2	909 019-1 Screw-Rd. Hd. 10-24 x 1/2	

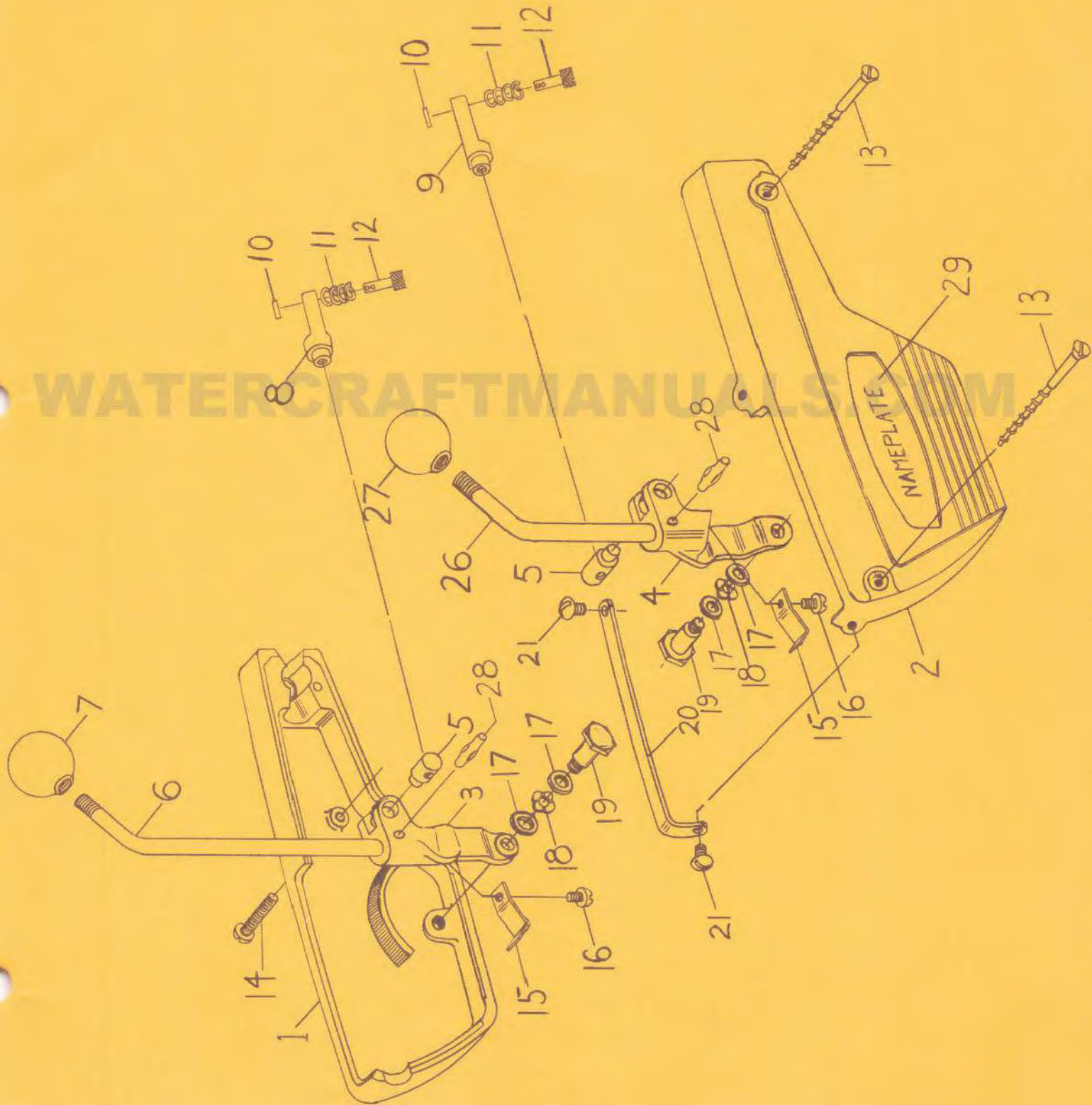
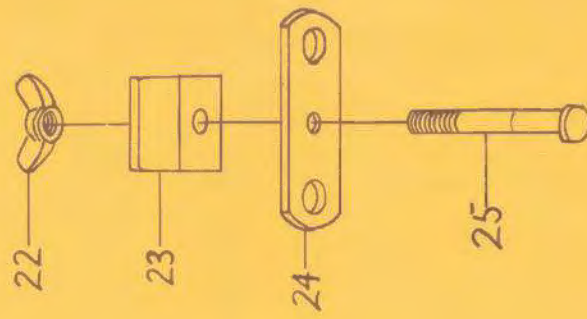

WATERCRAFTMANUALS.COM

SERVICE



BULLETIN

OLIVER OUTBOARD MOTORS

DIVISION OF OLIVER CORPORATION

108 SOUTH McCAMLY STREET • BATTLE CREEK, MICHIGAN

March 18, 1959
SM-1-55

TO: All Oliver Outboard Motor Distributors and Dealers
SUBJECT: Gear Shift Handle Assembly - Model B - 35HP Motors

To help provide better service with a smaller inventory of parts, a new #498 798JS Gear Shift Handle Assembly is being made available with instructions for installation. The #498 798JS Gear Shift Handle is a service replacement for the following part numbered Gear Shift Handles: #460 176JS, 460 096J, 460 568JS, 460 565JY, and 460 461JS. This service replacement Gear Shift Handle will replace any Gear Shift Handle installed on an Oliver Olympus Model B, B2, or B3 motor manufactured up to the present time.

This #498 798JS Gear Shift Handle can be installed for either right hand or left hand rotation propeller. The installation of the bell crank #460 458J determines the direction of the propeller rotation. For right hand rotation (counter rotating motors) install the bell crank with the straight side down and legs of bell crank protruding forward on the motor. For left hand rotation (standard motor rotation) install the bell crank with the straight side down and legs of bell crank protruding aft toward the rear of the motor.

It will be necessary to remove the powerhead from the lower unit to install a new gear shift handle.

Observe and make a note of the direction in which the legs of the old bell crank are installed. Be sure to install the new bell crank legs in the same direction or the motor rotation will be changed and the gear shift can not be adjusted. Remove the cotter pin attaching the bell crank to the upper shift rod. Remove nut and screw, on some motors lockwasher and screw, retaining the bell crank to shift handle shaft. Remove bell crank and flat washer and pull shift handle shaft out of the driveshaft housing.

INSTALLATION:

Place the Spacer Ref.#46 on the shift handle shaft. Lubricate shaft with lubriplate, and insert shaft into driveshaft housing. Push the shaft through the driveshaft housing. Check to see that the shift shaft bearings are in place and are not worn. Replace loose worn bearings. Install (1) Flat Washer Ref.#5, on the shift handle shaft and slip the bell crank on the shaft. Check the end play of the shift handle shaft. If the bell crank cannot be installed, Spacer Ref.#46 may not be required. Remove the larger spacer and use thin washers for adjustment. If the shift handle shaft has end play, remove the shaft from driveshaft housing and install thin washers like Ref.#5, sufficient to take up the end play. The old washers which were removed with the old handle may be used to make this adjustment. Reinstall the shift handle shaft into the driveshaft housing. Place (1) washer only on the inside of the driveshaft housing. Slip the bellcrank on end of shaft with the straight side down. Observe the bellcrank, one side is straight where as the other side is cut on an angle. Install the legs of the bellcrank in the same direction as the old one which was removed. Drive in the Spacer Ref.#45, between the bellcrank and shift handle shaft. If the spacer is loose, use a #10 flat washer to help fill the space completely or make a spacer to fit 3/16 x 5/8 x 11/32" with a 3/16" diameter hole in the center. Install the Allen head screw Ref.#7, and torque to 50-60 inch pounds. Attach the bellcrank to the upper shift rod, using 1/8" cotter pin. Bend the ends of the cotter pin and cut short so that the end will not extend up higher than the end of the shift rod. If the ends extend past the shift rod, they may hit the powerhead and prevent full movement of the shift handle. Install shift handle roller. Replace the powerhead. Adjust the gear shift linkage at the detent lever eccentric and shift rod connector, as both will be thrown out of adjustment when a new shift handle is installed.

#498 798JS Gear Shift Handle Assembly Includes the Following Parts:

- | | | |
|---|------------|-------------------------|
| 1 | #460 569JS | Shift Handle |
| 1 | 460 173J | Groove Pin-Shift Handle |
| 1 | 460 180J | Roller-Shift Handle |
| 1 | 460 458J | Bellcrank-Gear Shift |
| 1 | AI 012 | Screw-Gear Shift Shaft |
| 1 | 460 662J | Spacer-Bellcrank |
| 1 | 460 726J | Spacer-Gear Shift Shaft |
| 1 | DB 006 | Cotter Pin |
| 1 | | Instruction Sheet |

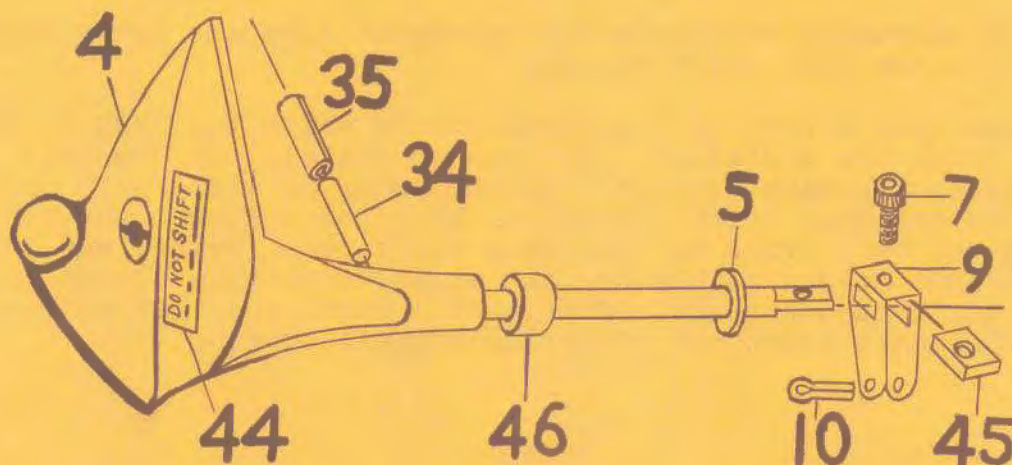

SERVICE



BULLETIN

OLIVER OUTBOARD MOTORS

DIVISION OF OLIVER CORPORATION

108 SOUTH McCAMLY STREET • BATTLE CREEK, MICHIGAN

SM-1-32

6-27-58

TO: All Oliver Outboard Motor Distributors and Dealers

SUBJECT: Adjustment of Cam-Throttle Control - Model B, 35 H.P. Motor

Field reports indicate that the cam-throttle control and the auxiliary arm, carburetor, cam follower may not be properly adjusted. This would result in poor engine performance at all speeds, especially noticeable at idling speeds. Check and adjust per following instructions.

1. Remove upper top shroud assembly to gain access to power head.
2. Advance throttle lever to high speed position.
3. Check carburetor throttle shutter to insure shutter being fully opened. A quick and easy way to check this is to sight along the top of the choke solenoid. The throttle shutter control lever should be in the position as illustrated in attached diagram. The throttle lever is 10° off parallel with the throttle shutter.
4. To adjust the carburetor throttle shutter for wide open, be sure throttle is in high speed position. Loosen jam nut and turn the throttle arm screw in or out as required until carburetor throttle shutter is fully open. Re-tighten the jam nut.
5. Move throttle lever to idle position.
6. Check position of the roller on the auxiliary arm carburetor cam follower. The roller should not be touching the cam, throttle control when throttle is in idle position to make this check. It may be necessary to release the idle adjustment screw located under the carrying handle near the throttle control gear.
7. Check position where roller makes contact with the cam-throttle control when throttle lever is advanced. The roller should contact the cam-throttle control at 1/4" to 1/2" from the idle end of the cam-throttle control. At that point the carburetor throttle shutter should start to open.

8. To adjust the cam-throttle control, loosen the retaining screw cam-throttle control which is nearer the idle end of the cam-throttle control. With this screw loose, move the cam-throttle control in or out as required. Adjust the cam-throttle control so that the roller will contact the cam-throttle control $1/4$ " to $1/2$ " from the idle end of cam when throttle is advanced. Re-tighten the retaining screw-throttle cam.
9. Recheck carburetor throttle shutter as outlined in Step 3.
10. If it is necessary to make adjustment of the cam-throttle control, it will be easier to make the adjustment with the front shroud removed. With the front shroud removed, the entire carburetor will be exposed. The slot in the throttle shaft for the throttle shaft return spring may be used to locate the position of the throttle shutter. The slot for the throttle shaft return spring is parallel with the throttle shutter.
11. Carburetor adjustment: With motor running at $3/4$ throttle, turn high speed adjustment knob slowly clockwise to lean until a definite drop in speed is noticed. Then turn high speed knob counter-clockwise to rich $1/4$ turn. That will be the proper high speed adjustment. Run motor at idle speed. Turn idle adjustment knob slowly clockwise to lean until a definite drop in speed is noticed or motor spits back. Turn idle adjustment knob $1/4$ turn counter-clockwise to rich. Motor should run smooth at this setting.

NOTE: Final adjustment should be between $3/4$ turn and $1-1/2$ turn on both needle valves.

TOP VIEW OF ROLLER-CARB.
CAM FOLLOWER

TOP VIEW OF CAM THROTTLE CONTROL
ADJUSTED TO LOW SPEED

TOP VIEW OF CAM THROTTLE CONTROL
ADJUSTED TO HIGH SPEED

RING & CLIP ASSY.

SCREWS

ARM-CARB. CAM FOLLOWER

ROLLER-CARB. CAM FOLLOWER

SPRING-AUX. ARM TO CARB. CAM.

SCREW & NUT- THROTTLE ARM ADJ.

AUX. ARM-CARB. CAM FOLLOWER

LINK-THROTTLE LEVER
TO AUX. FOLLOWER

CARBURATOR

THROTTLE SHUTTER CONTROL LEVER

$\frac{1}{4}$ " TO $\frac{1}{2}$ "

DISTANCE FROM CENTER LINE
OF ROLLER TO TIP OF CAM, WHEN
ADJUSTED TO LOW SPEED

POSITION OF SHUTTER LEVER RELATIVE TO
TOP OF CHOKE SOLENOID, WHEN CARB.
THROTTLE SHUTTER IS WIDE OPEN & THE
CAM THROTTLE CONTROL AT HIGH SPEED

LINK CHOKE ROD
CHOKE SOLENOID

PHANTOM LINES INDICATE
SHADED AREA ON DIAGRAM AT RIGHT

POSITIVE IDLE ADJUSTMENT
SCREW

POSITION OF POWER HEAD WITH TOP SHROUD OFF
FROM WHICH SHADED AREA CAN BE SEEN THROUGH

WATERPUMPMANUALS.COM

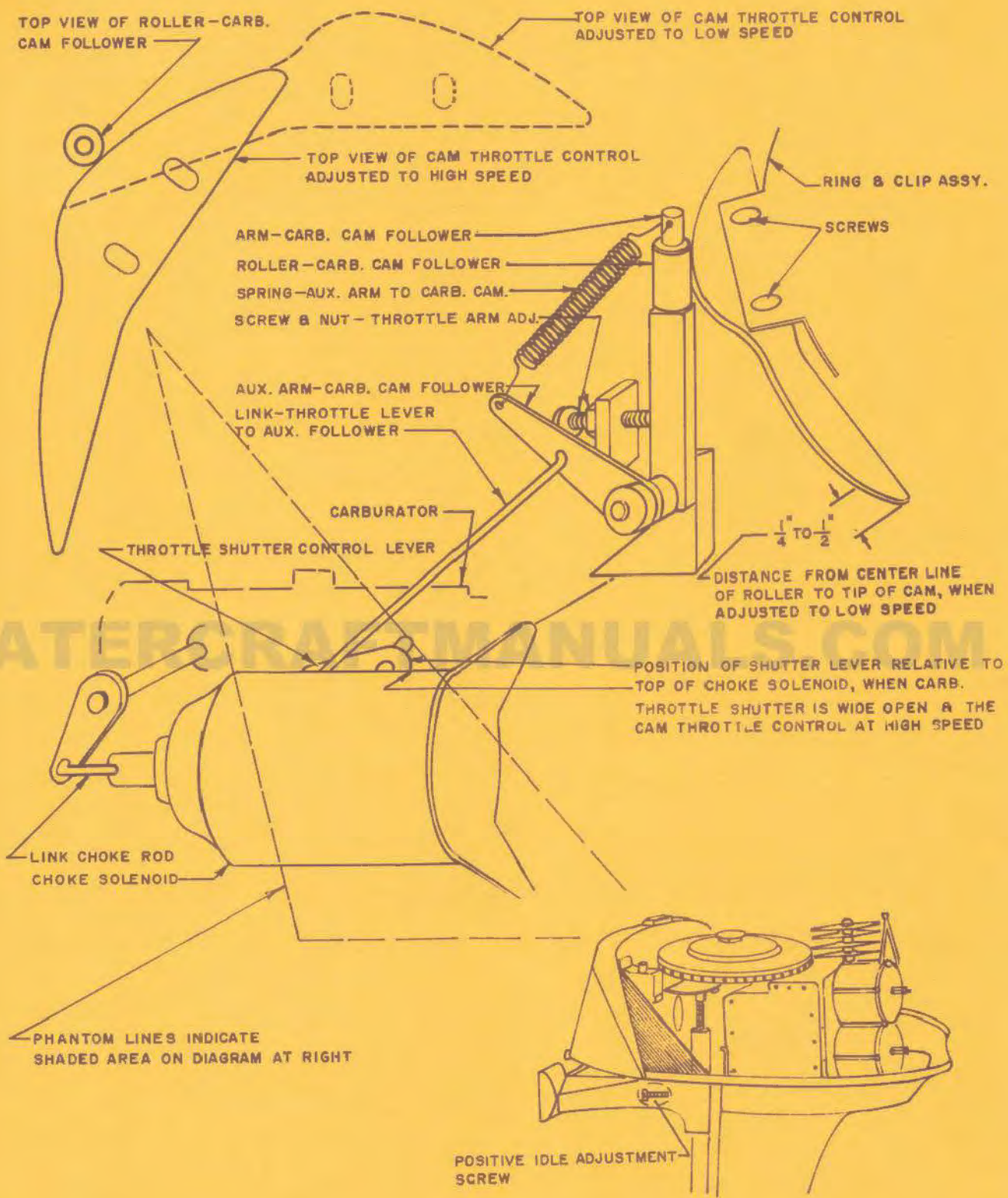

SERVICE



BULLETIN

OLIVER OUTBOARD MOTORS

DIVISION OF OLIVER CORPORATION

108 SOUTH McCAMLY STREET • BATTLE CREEK, MICHIGAN

SM-4-38
August

TO: All Oliver Outboard Motor Distributors and Dealers

SUBJECT: Gear Shift Adjustment Model J-2, J-3, J-4 - 5.5 and 6 HP motors

Numerous requests have been received asking for instructions to properly adjust the Gear Shift Linkage. This Service Bulletin will furnish this instruction.

First, find the neutral position of the Clutch Sleeve. This has always presented a problem. This problem has been solved. A new special tool, Kent-Moore, #J-7414 has been designed to aid in finding the neutral position of the clutch sleeve. The total stroke of the lower shift rod is one-half inch. The neutral position of the clutch sleeve is the center of this stroke. Kent-Moore Tool, #J-7414, Shift Linkage Adjustment Gauge, when used per instructions, will locate the center of the stroke of the lower shift rod.

Order special service tools from Kent-Moore Organization, Inc., 28635 Mound Road, Warren, Michigan. The list price of the J-7414 Tool is \$.75 each.

Instructions for Gear Shift Adjustment

1. Remove the two screws and the shift adjust port cover located on the left hand side of the gear case, approximately 3 inches above the cavitation plate. See Figure 2.
2. Use one of the shift adjust port cover screws and fasten the Kent-Moore Tool #J-7414 shift linkage adjustment gauge at the front shift adjust cover screw hole. The pointed tongue of gauge to be on the top side. See Figure 2.
3. Place Shift Handle in Forward position at the same time turn the prop.
4. Loosen the shift rod coupling screw, See Figure 2.

5. Lift the lower shift rod and coupling up as far as it will go. At the same time joggle the prop. See Figure 2.
6. Scribe or mark the shift rod coupling along the top edge of J-7414 Gauge.
7. Move shift handle to neutral position.
8. Move the shift rod coupling down so that the scribe mark will be just visible above the center of the J-7414 gauge. See Figure 2.
9. With shift handle in neutral position and scribe mark at the center of J-7414 Gauge, tighten the shift rod coupling screw. This completes the finding and adjusting the gear shift for neutral position.
10. Remove the top shroud.
11. Loosen the shift stop adjust nuts. These are located on the lower shroud near the gear shift handle.
12. Screw the shift stop adjust screws away from the gear shift handle. See Figure 1.
13. Move the gear shift handle to forward position. At the same time joggle the prop to engage the clutch sleeve.
14. Check the shift rod coupling. The scribe mark should be in the same position coupling was in when coupling was marked in Step #6. If not see correction below.
15. Screw the forward shift stop adjust screw in until the screw just contacts the shift handle and 1/4 turn more after contact.
16. Tighten the forward shift stop adjust nut. Hold the screw so that adjustment will not change while tightening the nut.
17. Move the gear shift handle in reverse position at the same time joggle the prop to engage the clutch sleeve.

18. Check the shift rod coupling. The scribe mark should be visible just below the J-7414 Gauge. If the mark is not below the J-7414 gauge, and the shift handle is hitting the lower shroud, it will be necessary to file the lower shroud to give more movement of the shift handle toward the reverse position.
19. Screw the reverse shift stop adjust screw in until the screw just contacts the shift handle and 1/4 turn more after contact.
20. Tighten the reverse shift stop adjust nut.
21. Tank test motor, check gear shift in both forward and reverse for going in and coming out of gear. If gear shift still is not properly adjusted see the following problems.

Problem: Gear shift will not stay adjusted or can not be adjusted to go into forward on 5.5, J-2 and 6 HP, J-3.

Cause: Bent lower shift rod. This is caused by forcing shift handle when motor is not running.

Correction: Remove gear case and replace the lower shift rod with the 6 HP J-4 heat treated and hardened #496 309-J lower shift rod and #496 308-J Yoke. It is necessary to change both yoke and rod because of design changing from a coarse to a fine thread.

Problem: Gear Shift can not be adjusted to go into reverse position.

Cause: Lower shift rod screwed too far into the clutch yoke.

Correction: A. Turn lower shift rod counter clockwise to give more adjustment.

Cause: Seal tube packing nut loose.

a. Tighten seal tube packing nut.

Cause: Two seals used in Seal Tube Packing nut.

a. Remove one seal and retighten seal nut.

Figure No. 1 - View "J" Model Gear Shift Handle and Cutaway View of Stop Screws.

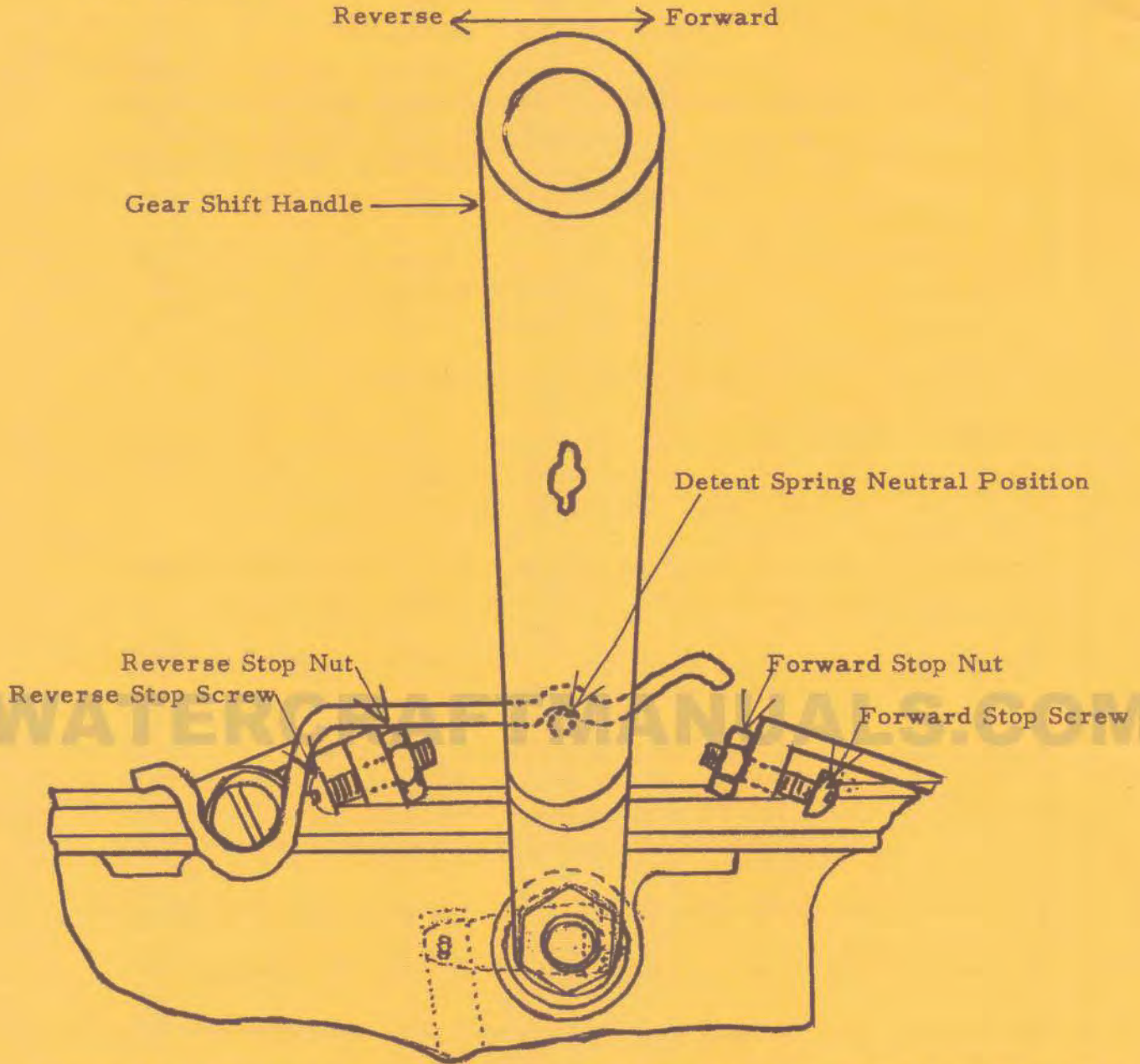
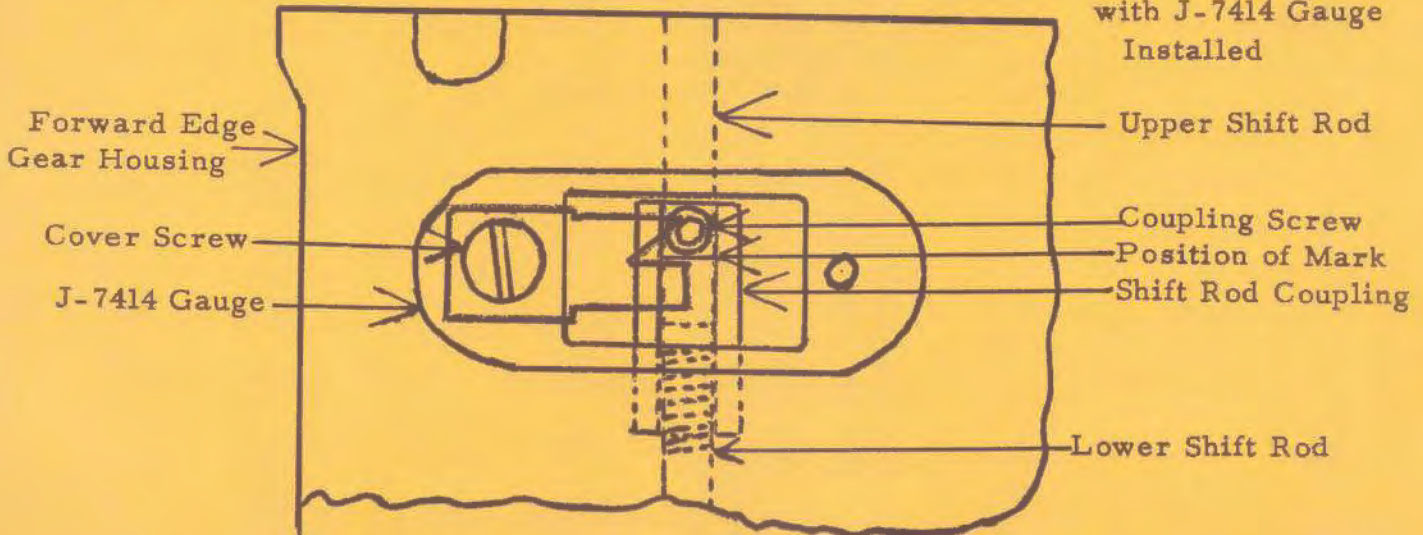

Figure No. 2 Section of Lower Left Side of Gear Case Showing Adjust Port Hole with J-7414 Gauge Installed



SERVICE



BULLETIN

OLIVER OUTBOARD MOTORS

DIVISION OF OLIVER CORPORATION

108 SOUTH McCAMLY STREET • BATTLE CREEK, MICHIGAN

February 20, 1959
SM-1-54

TO: All Oliver Outboard Motor Distributors and Dealers

SUBJECT: Starter Bracket Service Assembly - Model B, 35HP Motors

To help provide better service with a smaller inventory of service parts, a new starter bracket service assembly is being made available with instructions for installation.

The 1959 Model B motors are manufactured with a new electric starter motor incorporating nine (9) tooth pinion gear. To use the (9) tooth pinion, the starter bracket was machined to move the starter aft .110". A spacer washer Part #460 655J is placed between the starter bracket and front shroud. See Fig. 1, Ref. 1 for location.

To use the same starter bracket with the starter with ten (10) tooth pinion installed on 1958 Model B motors, place the two (2) spacer washers in location shown in Fig. 1, Ref. 2, between the starter bracket and cylinder block.

For Model B motors with long crankshafts, Serial Numbers 300001 to 304000 and 307001 to 307442, order #498 797JS Starter Bracket Assembly which includes the following parts.

- 1 #460 651J Starter Bracket
- 2 460 655J Spacer Washer - .110 thick

For Model B motors with short crankshafts, Serial Numbers 304001 to 307000 and 307443 and up, order #498 796JS Starter Bracket Assembly which includes the following parts.

- 1 #460 647J Starter Bracket
- 2 460 655J Spacer Washer - .110 thick

To change the #492 333JS cranking motor with ten (10) tooth pinion to incorporate nine (9) tooth pinion, it will be necessary to change the starter bracket and use the appropriate starter bracket assembly as listed in this bulletin.

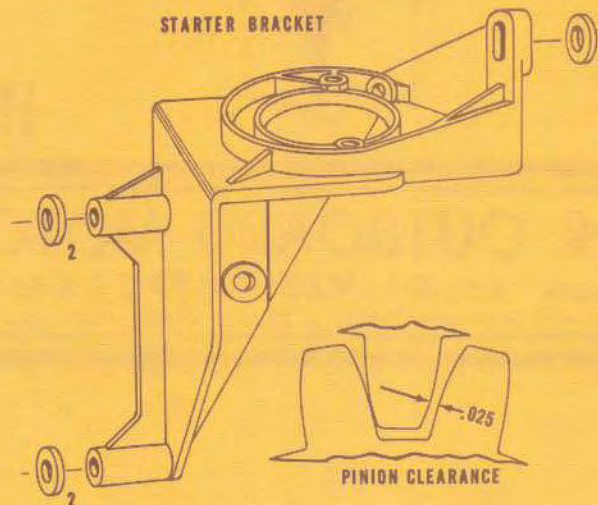

Order a new #498 793JS Drive Assembly (Delco Part 1946072).

Loosen the nut at the end of the armature and remove the old (10) tooth pinion drive unit. The drive unit can be slipped off the shaft after the nut is loosened.

Install the new (9) tooth pinion drive assembly on the armature shaft and tighten the nut.

Mount the starter on the bracket using the two thru bolts. The pinion should mesh with the ring gear at least 2/3 of the way.

The back lash on the pinion and ring gear should be set with a feeler gauge. There should be .025 clearance between tooth mating or engagement. The bolt holes in the starter bracket are large enough to allow for a small adjustment. Loosen the large bolts attaching starter bracket to crankcase. Move the starter in or out as required and tighten the bolt while holding the starter in position for the correct clearance.

Service Department

SERVICE



BULLETIN

OLIVER OUTBOARD MOTORS

DIVISION OF OLIVER CORPORATION

108 SOUTH McCAMLY STREET • BATTLE CREEK, MICHIGAN

January 13, 1959
SM-1-53

TO: All Oliver Outboard Motor Distributors and Dealers

SUBJECT: Test Tank Operation of the 35HP Motor.

We have found in test tank operation of the 35HP motor with the front shroud removed, that we are having cases of damaged or fractured starter brackets and port brackets, which retain the upright throttle arm.

We would like to recommend that you use a brace across the engine from the starter bracket to the throttle bracket. This brace may be either made of wood or metal. The brace can be attached to the starter bracket and throttle bracket with a standard 5/16" bolt. This would permit accessibility to the necessary adjustments prior to the installation of the front shroud assembly.

A fracture of the starter bracket or throttle bracket might not be obvious in the initial test of the engine. After the shrouds have been installed and the engine placed back in operation on the boat, it is possible that in a period of time the vibration will cause complete failure.

See sketch on Page 2.

Service Department

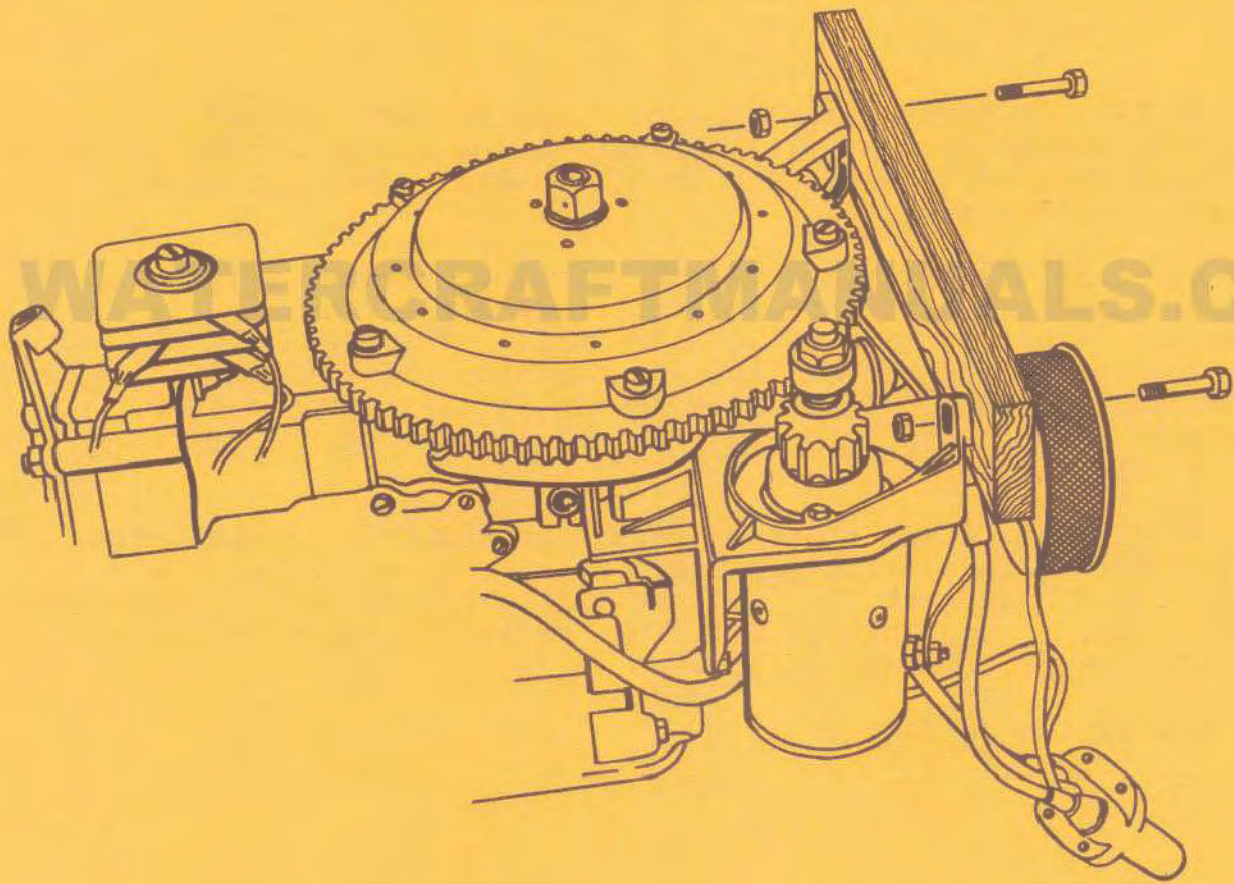

SERVICE



BULLETIN

OLIVER OUTBOARD MOTORS

DIVISION OF OLIVER CORPORATION

108 SOUTH McCAMLY STREET • BATTLE CREEK, MICHIGAN

January 8, 1959

SM-1-52

TO: All Oliver Outboard Distributors and Dealers

SUBJECT: Center Main Bearing and Retainer-Model "K" Motors

The center main bearing race #492 217JA is no longer available for service repairs. In the future #492 432J Center Main Bearing Race will be furnished for service replacement.

See illustration for changes which were made. The thrust washer retaining ears were removed from the #492 217JA Race to make the #492 432J Race.

It will be necessary to use a #492 393JSA Center Main Bearing Retainer Assembly with #492 432J Center Main Bearing Outer Race.

To make #492 393JSA Retainer from a #492 393JS Retainer, which was installed in the K, K2, and K3 motors, follow these instructions. (See illustration on Page 2).

1. Remove the Center Bearing Retainer Assembly from the motor and separate the two halves.
2. Place the larger part on a work bench and measure in $3/32$ " from the flat surface toward the Center Main Bearing Dowel.
3. Mark this location in line with the Center Main Bearing Dowel. See illustration of #492 393JSA.
4. Drill a $3/32$ " dia. hole $1/2$ " deep. CAUTION: Use a stop on the drill to obtain correct depth.
5. Increase the size of the $3/32$ " dia. hole. Drill to #30 drill size .1285, $7/16$ " deep. CAUTION: Use a stop on the drill to obtain correct depth.

6. Repeat steps 1 thru 5 on the other side of retainer.
7. Drive two (2) DE-005 Drive Pins into the two holes.
NOTE: Drive Pins should protrude $3/32"$ to $7/64"$.

The drive pins take the place of the thrust washer retaining ears on the Center Main Bearing Race. Be sure that drive pins do not interfere with the bearing race.

NOTE: A piece of $1/4"$ tubing may be cut to the proper length to serve as a stop for the drill, or drill bit may be adjusted in the chuck to obtain the proper depth.

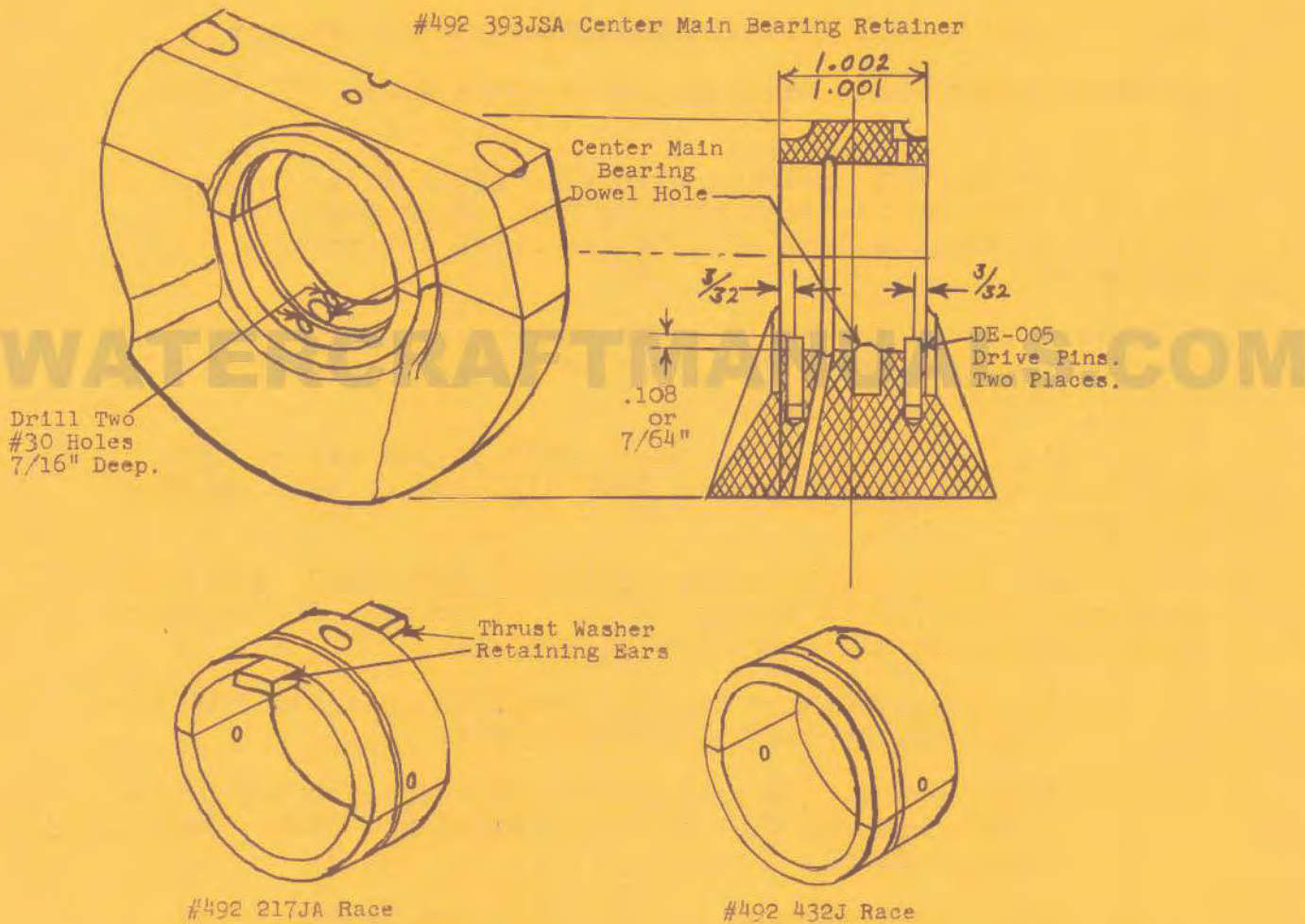

Service Department



OLIVER OUTBOARD MOTORS

DIVISION OF OLIVER CORPORATION

108 SOUTH McCAMLY STREET • BATTLE CREEK, MICHIGAN

December 19, 1958
SM-1-51

TO: All Oliver Outboard Motor Distributors and Dealers

SUBJECT: Modification of K2, K3, K4, and K5 Transmission Housing Water Inlet.

Additional testing has revealed that when operating the K Model motors in waters where moss and weed growth is massive, the water inlet may become plugged. This may cause the engine to overheat. To prevent this condition, modify the water inlet as follows.

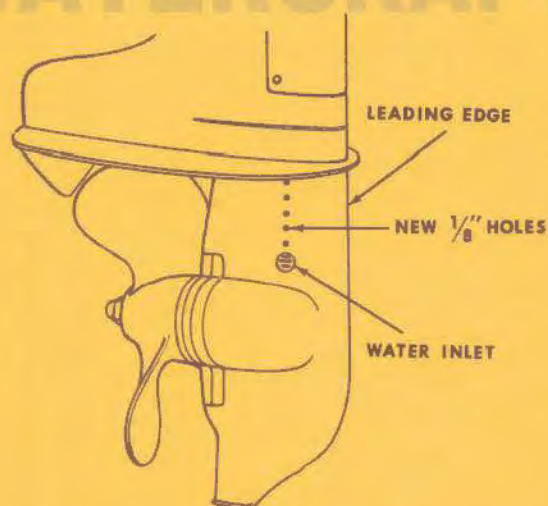

1. Measure the distance from the leading edge of the transmission housing to the center of the water inlet hole. This distance is approximately $2\frac{1}{2}$ " for the K2 motors and 2" for the K3, K4, and K5 motors.
2. Draw a line parallel to the leading edge of the transmission housing from the center of the water inlet hole up to the cavitation plate: CAUTION: Do not use a metal scribe. Use a soft lead pencil so as not to scratch the paint.
3. Measure up along this line from the top edge of the water inlet hole $\frac{5}{16}$, $\frac{5}{8}$, $\frac{5}{16}$, $1\text{-}1/4$, and $1\text{-}9/16$ inches. Mark the five (5) locations with a center punch.
4. Drill five (5) $1/8$ inch diameter holes into the water passage.
5. Measure the opposite side of the housing and repeat steps 2, 3, and 4.

SERVICE



BULLETIN

OLIVER OUTBOARD MOTORS

DIVISION OF OLIVER CORPORATION

108 SOUTH McCAMLY STREET • BATTLE CREEK, MICHIGAN

SM-1-50
10-27-58

TO: All Oliver Outboard Motor Distributors and Dealers

SUBJECT: Service Tools and Equipment

Now that the seasonal lull is upon us and you are formulating your plans for your '59 program -- it is a good time to take a look at your Service Repair Shop. Is it properly equipped -- Efficiently arranged -- and are you getting the profit you should from this very vital part of your business? Good Service is your insurance of Good Business in the future. One of the many profit factors to be yours at this time of year is offering a Winter Storage Program to your Oliver Outboard Motor customers.

To help you evaluate your present service facilities we are sending you this suggested layout which we believe will serve adequately for the average repair shop. In this layout we have listed under the heading of equipment, the major items that should be included as part of your Outboard Motor Repair Shop.

We are attaching a bulletin, showing pictorial views, of the Oliver Kit of Special Tools. This bulletin explains the proper use of these tools. To further assist you, we will be happy, upon request, to forward blueprints of the motor stand and rack if you find these items to be of value to you.

Remember, GOOD SERVICE retains your customers of today and builds your SALES OF TOMORROW.

Service Department

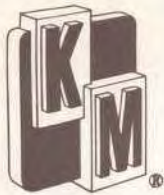

ORDER FORM



OLIVER OUTBOARD MOTOR TOOLS

SHIP TO _____
 ADDRESS _____
 CITY _____ STATE _____

TERMS
 Check Attached \$ _____
 C.O.D. \$ _____

All Shipments F.O.B. Jackson, Michigan
 All Prices Subject to Change Without Notice

QUANTITY	TOOL NO.	DESCRIPTION	PRICE	TOTAL
<input type="checkbox"/>	EG-OL-58-1	OLIVER SPECIAL SERVICE TOOLS CONSISTS OF ONE EACH OF THE FOLLOWING	SPECIAL GROUP PRICE \$61.10	
	J 7368	Flywheel Remover.....	\$5.70	
	J 6125-1	Slide Hammer.....	3.40	
		6 HP		
	J 7375	Piston Ring Compressor.....	2.50	
	J 7369	Pinion Carrier Sleeve Bearing Remover and Replacer.....	2.70	
	J 7373	Drive Shaft Upper Bearing Remover.....	3.95	
	J 7374	Drive Shaft Upper Bearing Replacer.....	2.25	
	J 7414	Shift Linkage Adjustment Gauge.....	.75	
		16 HP		
	J 7380	Piston Ring Compressor.....	2.65	
	J 7366	Propeller Shaft Needle Bearing Remover.....	6.00	
	J 7367	Propeller Shaft Needle Bearing Replacer.....	3.50	
	J 7370	Drive Shaft Nut Retainer Bearing Spanner Wrench.....	4.00	
	J 7381	Drive Shaft Bearing Remover and Replacer.....	2.50	
		35 HP		
	J 7360	Pinion Bearing Remover and Installer.....	4.00	
	J 7361	Upper Drive Shaft Bearing Remover.....	4.00	
	J 7362	Piston Ring Compressor.....	2.90	
	J 7363	Valve Stem Gauging Tool.....	10.25	
	J 7365	Upper Drive Shaft Bearing Replacer.....	4.15	
	J 7372	Reverse Pinion Bearing Replacer.....	3.20	
	J 7388	Valve Seat Installer.....	3.75	
		Price if purchased separately	\$72.15	

SIGNED _____

TOTAL _____

STATE AND/OR LOCAL USE TAX WILL BE ADDED TO INVOICE IF APPLICABLE

ORDER SUBJECT TO CONFIRMATION BY

KENT-MOORE ORGANIZATION, INC.

28635 MOUND ROAD

WARREN, MICHIGAN

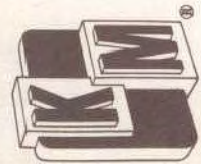

KENT-MOORE SERVICE TOOLS... for Oliver Outboard Motors

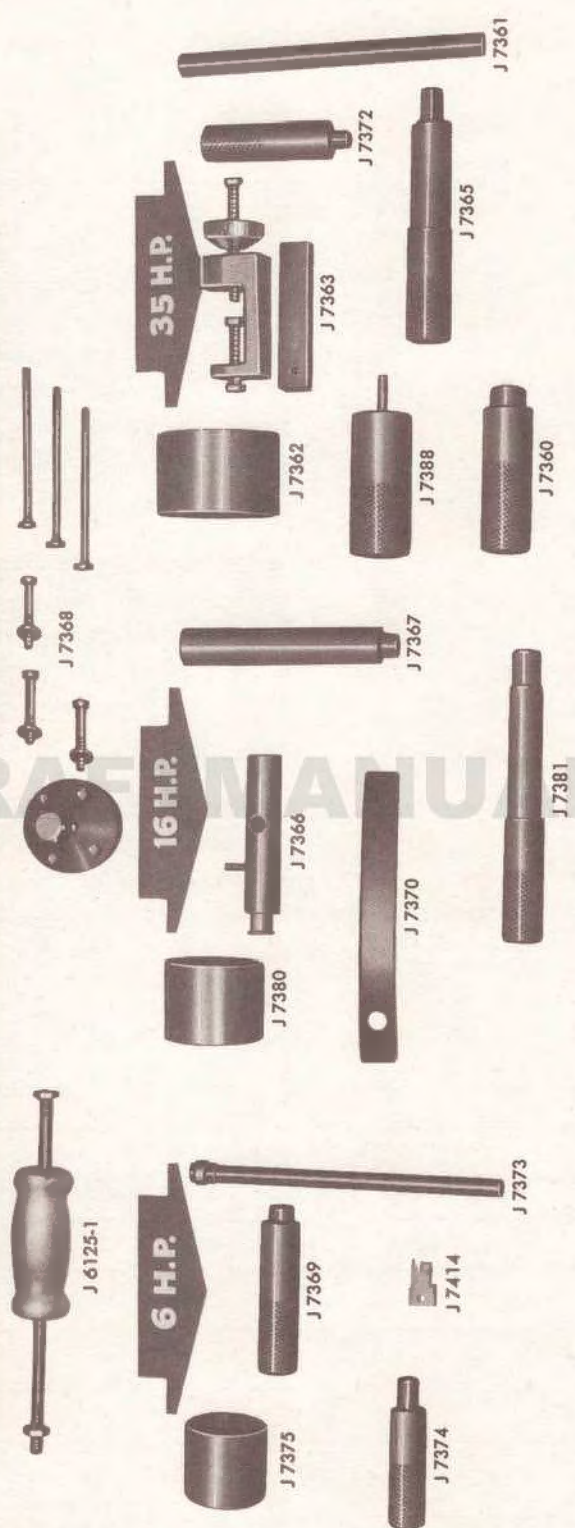

KENT-MOORE ORGANIZATION, INC.
28635 MOUND ROAD • DETROIT, MICHIGAN



OLIVER OUTBOARD MOTORS

DIVISION OF OLIVER CORPORATION
108 SOUTH McCAMLY STREET • BATTLE CREEK, MICHIGAN

SM-1-37
August

TO: All Oliver Outboard Motor Distributors and Dealers

SUBJECT: Float Setting All Models "J" and "K" Motors

The float setting is the same on all Model J, 5.5 and 6 HP and Model K, 15 and 16 HP motors.

A constant gasoline level in the bowl and all channels of the carburetor is maintained by Inlet Needle and Seat Assembly, Ref. A and Float Ref. D. An improperly adjusted float level or a leaking inlet needle valve will cause a motor to run erratically. A high float level will cause the motor to run rich with possible flooding. A low float level will cause the motor to run lean. This is most noticeable at the intermediate range between high and low speed. A leaking inlet needle valve will cause flooding at low speeds.

Problem: Float Setting

Correction:

1. Remove carburetor from motor.

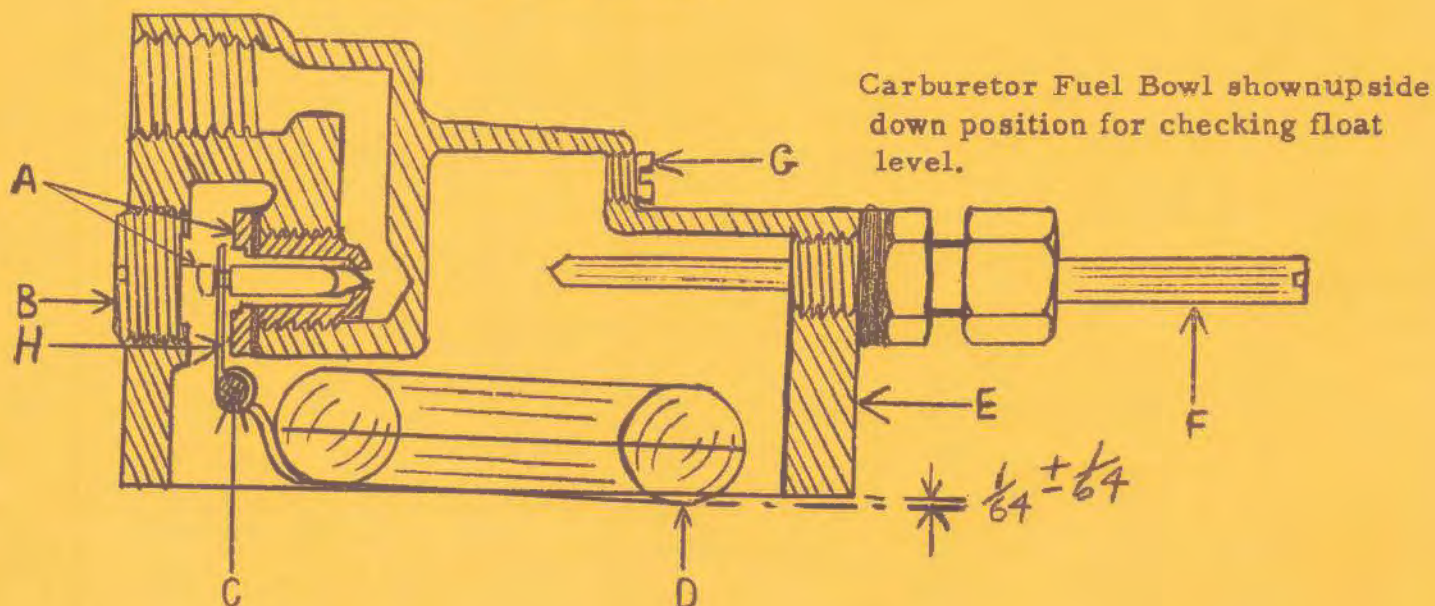

2. Turn high speed adjustment screw counter clockwise 4 to 5 times. This is to prevent damage to the high speed adjustment needle and seat when fuel bowl is separated from the upper body.
3. Remove the four (4) fuel bowl retaining screws.
4. Separate the fuel bowl from the upper body and hold the fuel bowl upside down in an inverted position and check the float level.
5. The lowest point of the float at the free end should project 1/64" below rim of float bowl. See Illustration, Ref. D.
6. If resetting is required, remove float level pinion pin, Ref. C. and float, Ref. D from fuel bowl and bend vertical float level tang, Ref. H at point nearest the juncture of the horizontal float flange. Extreme care must be exercised to insure that the arms of the forked float level be in the same plane.

Problem: Fuel level continues to rise beyond float setting point or carburetor floods and flows over.

Cause: Inlet needle and seat leaking.

Correction: Remove inlet needle and seat, clean their seating surfaces with a clean soft cloth. Place inlet needle in its seat and tap very lightly turning inlet needle with thumb and forefinger several times to reseal. Reinstall and check float level. If proper fuel level is not maintained, install new inlet needle and seat assembly. Caution: Do not change float setting from manufacturer's specifications.

hbd

SERVICE



BULLETIN

OLIVER OUTBOARD MOTORS

DIVISION OF OLIVER CORPORATION

108 SOUTH McCAMLY STREET • BATTLE CREEK, MICHIGAN

June 26, 1958

SM-1-36

TO: All Oliver Outboard Motor Distributors and Dealers

SUBJECT: Installation Instructions - New Tilt Lock Assembly
J-2, J-3 and J-4 Oliver Outboard Motors

The new Tilt Lock Assembly is now available and may be installed on all Model J, 5-1/2 and 6 horsepower motors manufactured by The Oliver Corporation since 1956.

Order by Part #498 678-JS Tilt Lock Assembly, which list at \$.90.

This assembly includes the following parts:

1	494 109-J	Arm - Tilt Lock
2	932 000-1	Pin - Cotter
1	494 110-J	Spring - Tension Tilt Lock
1	494 111-J	Chip - Tilt Lock
1	426 296-1	Screw - Self Tapping

1. Cut out Template "A".
2. Tilt motor up into position as illustrated.
3. Apply Template "A" to the Swivel Bracket on the Starboard Side. This is the side on which the Shift Handle is located. Mark the center location of the three holes, E, F and G
4. Drill Holes E, F and G.
5. Apply reverse side of Template "A" to the Swivel Bracket on the Port Side and with a center punch mark the location of the 1/4" diameter hole "E" only.
6. Drill the 1/4" diameter hole "E" on the Port Side of the Swivel Bracket
7. Install the Arm-Tilt Lock in Hole "E" with the end drilled for the cotter key inserted through the 1/4" diameter hole.

8. Install the Cotter Keys with the head down as shown in the attached drawing. It is important to have the head of cotter key down otherwise the spring will pull the Arm-Tilt Lock in the wrong direction.
9. Hook the rounded end of the tension spring into the head of the cotter key nearest the bend of the Arm-Tilt Lock.
10. Hook the squared end of the tension spring into the forward $5/32$ " diameter hole "F". Bend a hook at the end of a wire and use it to stretch the spring into place.
11. Install the Clip Tilt Lock using the self tapping screw provided. Screw the self-tapping screw into the $1/8$ " diameter hole "G". After starting the screw fasten the arm-tilt lock into the clip. This will hold the clip in the correct position. Then tighten the self-tapping screw.
12. Cut out Template "B".
13. Apply Template "B" to Star Board Clamp Bracket in position shown on drawing with slot in template down.
14. Mark center location of Notch using a center punch.
15. Use a $1/4$ " diameter drill and drill a hole $3/16$ " deep into the Star Board Clamp Bracket. Be careful not to drill too deep. Use the side of the drill and cut out the top edge of this hole so that the Arm-Tilt Lock will fit into the notch.
16. Bend the Tilt-Lock Arm so that it will drop into notch and lock in tilt position.

TEMPLATE 'A'

TO FIND LOCATION OF HOLES FOR TILT LOCK ASSEMBLY

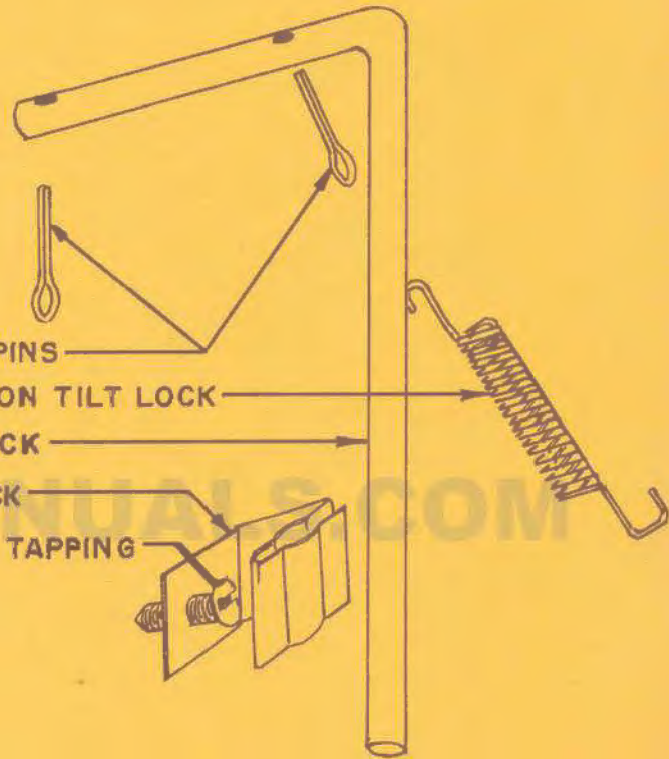
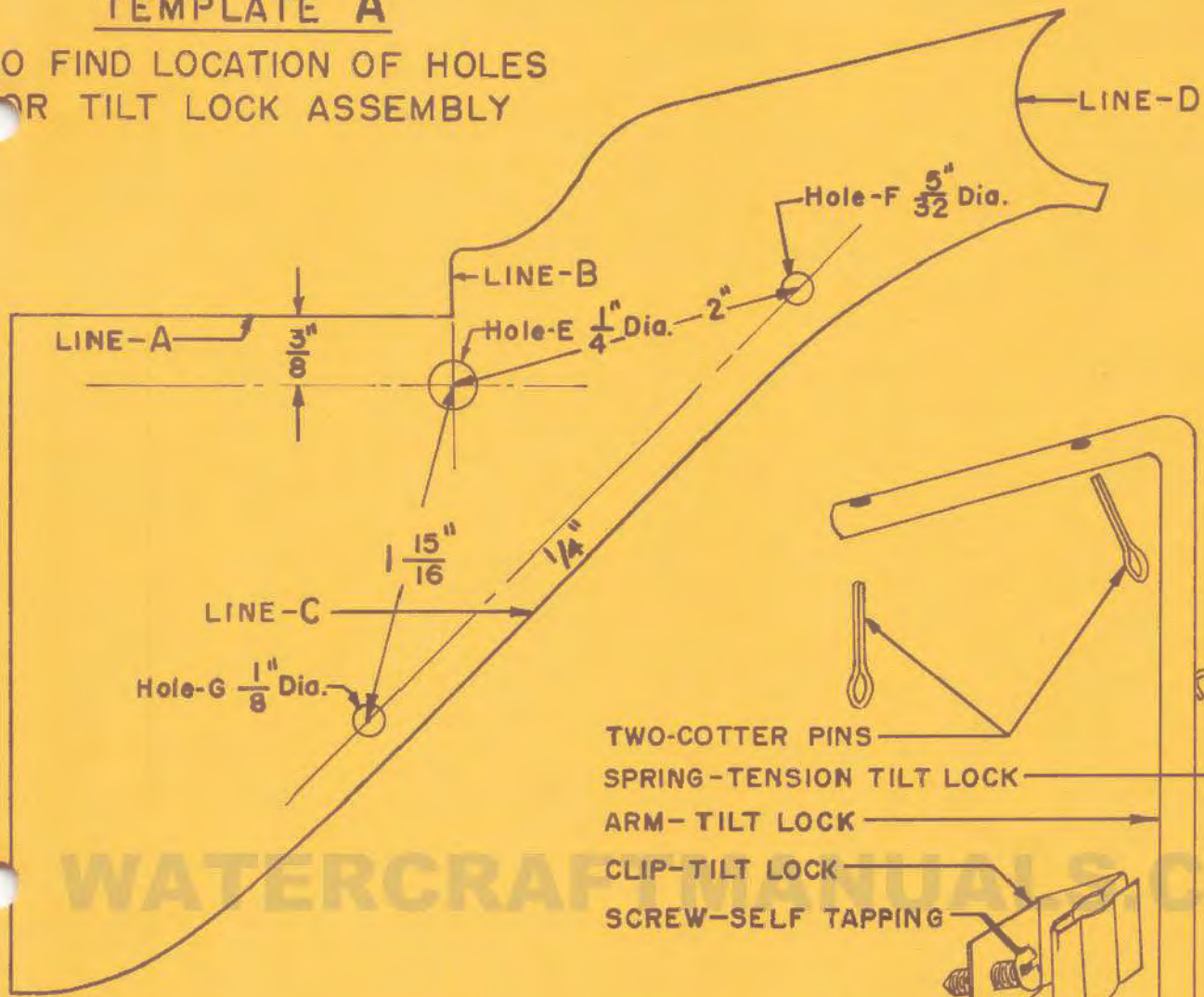

TILT LOCK ASSEMBLY PARTS

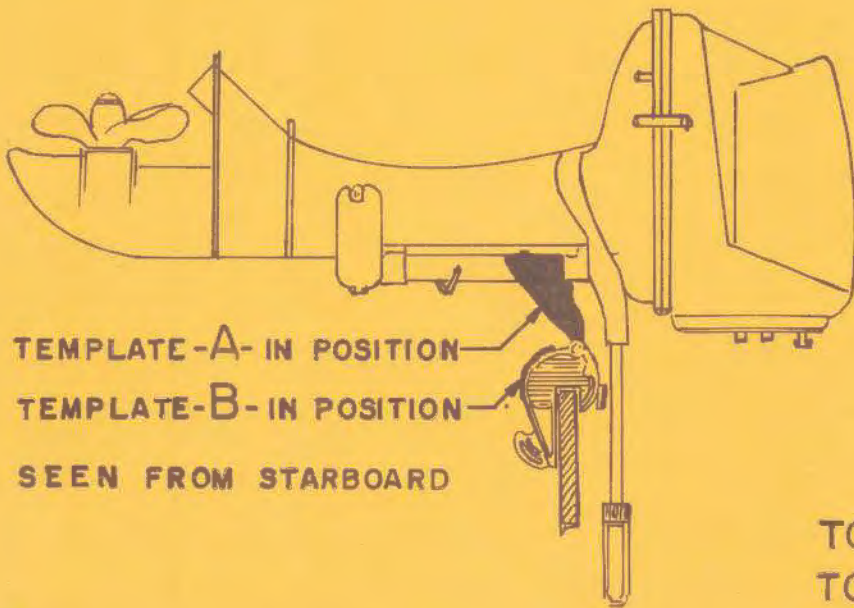

TEMPLATE 'B'

TO FIND LOCATION OF NOTCH TO RETAIN TILT LOCK ARM





SERVICE

BULLETIN

OLIVER OUTBOARD MOTORS

DIVISION OF OLIVER CORPORATION

108 SOUTH McCAMLY STREET • BATTLE CREEK, MICHIGAN

SM-1-33

6-27-58

TO: All Oliver Outboard Motor Distributors and Dealers

SUBJECT: Installation of new Tilt Lock on K2, K3, and K4 Oliver Motors

We now offer a kit, Part #498 675JS Tilt Lock Assembly which lists at \$1.40 and includes the following parts.

1	#460 298J	Knob-Choke Control-Manual
1	494 296J	Arm-Tilt Lock
1	494 297J	Special Rivet-Tilt Lock
1	494 298J	Spring-Tilt Lock
1	932 000-1	Cotter Pin (1/16 dia. x 1/2 lg.)
1	EB 004	Nut #10-24 Elastic Stop
1	909 022-1	Slotted Rd. Hd. Mach Screw #10-24 x 3/4
1	498 427J	Template-Hole location for Tilt Lock (Blue print only)
3	BA 004	Washer-Use as req'd.

This assembly will provide a positive lock that will keep the motor tilted up in a horizontal position. It will modernize and bring the latest advances in engineering design to the owners of Oliver Model K Motors. It will eliminate the use of a stick or other means of keeping the motor tilted. It is inexpensive and easy to install. The tools required are a drill, either hand or power, two (2) twist drill bits, sizes 11/64 and 1/4 inch diameter, six (6) inch rule, common screw driver, 3/8 wrench, and pair of pliers.

1. On the following page you will find a drawing which is designed to be used as a template. Cut along the solid line and use the paper as a template. Disregard the measurements when using the template. The measurements are given to assist in laying out the hole locations without using the template. The dotted lines show the position of a 6 inch rule when laying out hole locations by using a 6 inch rule.
2. Tilt the motor up into a horizontal position and turn the power head away from the shift handle side. This will expose the swivel bracket and give clearance for drilling the holes in the swivel bracket.

3. Apply the template to the swivel bracket on the starboard side. This is the side on which the shift handle is located. The heavy solid lines are the locating points on the template. The line marked "A" is placed below and in line with the upper pivot tube bearing and the aft edge of the stop on the swivel bracket. The height of the swivel stop varies. For this reason the upper pivot tube bearing is used as a locating point. The line marked "B" is aligned with the angling edge of the swivel bracket. The hole marked "C" on the template should be cut out of the template. Then place this hole over the hole in the swivel bracket. With the template held in position, mark the locations for 11/64 and .260/.256 diameter holes using a center punch and hammer.
4. Drill the 11/64 and .260/.256 diameter holes as marked.
5. Assemble the tilt lock as illustrated. The EB 004 nut is screwed on to the #909 022-1 Screw up to within 3/16 inch of the screw head.
6. Insert the screw into the hole in the center of the #494 296J Arm-Tilt Lock. Screw the #460 298J Knob on to the end of #909 022-1 Screw and tighten with a pair of pliers. Use a rag or cardboard to protect the knob from damage.
7. Insert the #494 297J Special Rivet in the hole at the end of the #494 296J Arm-Tilt Lock and install the completed assembly on the inside of the swivel bracket with the special rivet. The rivet is inserted from the inside protruding out, using the .260/.256 hole which was drilled in Step 4.
8. Use PA 004 Washers as required to adjust the rivet for length.
9. Insert the #932 000-1 cotter key through the 1/26" hole in the special rivet and spread the ends of the cotter key.
10. Install the #494 298J Spring-Tilt Lock with square end through the 11/64" diameter hole and hook the rounded end over the #909 022-1 Screw. A wire with a hook bent on the end will be found useful in stretching the spring over the end of the screw.
11. Check to see that the tilt lock arm rests in the stern bracket when motor is tilted. The arm should work free and easy without binding.

498427J TEMPLATE — HOLE LOCATION FOR TILT LOCK

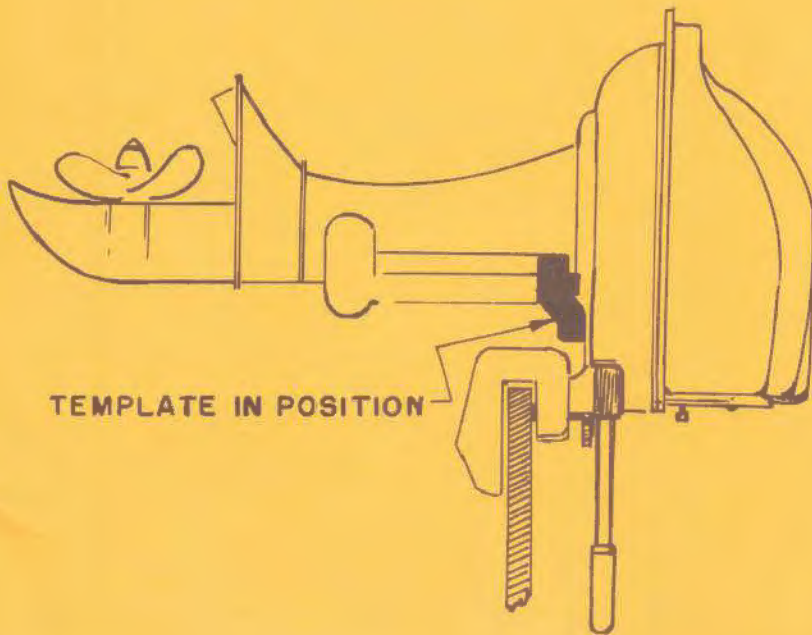
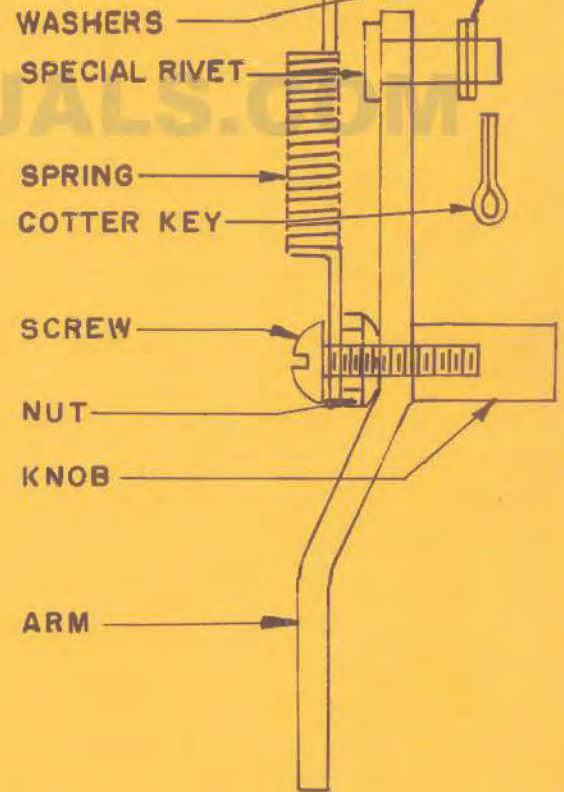
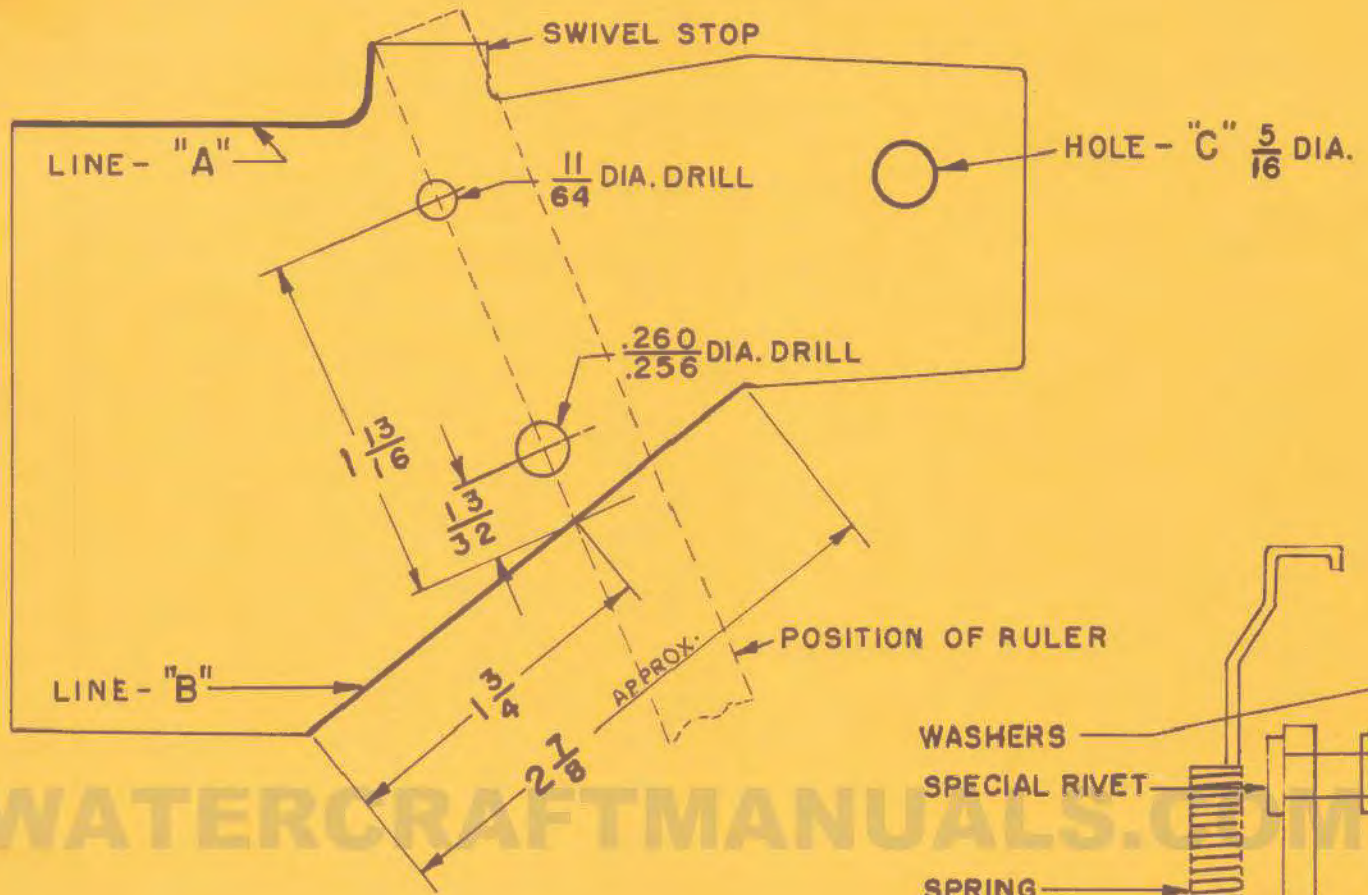

TILT LOCK ASSEMBLY

SERVICE



BULLETIN

OLIVER OUTBOARD MOTORS

DIVISION OF OLIVER CORPORATION

108 SOUTH McCAMLY STREET • BATTLE CREEK, MICHIGAN

June 26, 1958
SM-1-35

TO: All Oliver Outboard Distributors and Dealers

SUBJECT: Grease Leaking From Grease Filler Plugs

Complaints have been received from dealers that grease leaks from the grease filler screws on new motors while on display. This is reported most often on Model K Motors.

The usual cause of grease leaking from a grease plug screw is a damaged or improperly installed seal.

On Model K, 15 and 16 horsepower motors, remove the Grease Plug #496 054-J and replace the Grease Seals. Use a #496 111-J Grease Seal Washer and a #498 009-J "O" Ring Grease Seal on each grease plug. The combination of the two seals will give a positive seal.

On Model J, 5-1/2 and 6 horsepower motors, and Model B, 35 horsepower motors, replace the "O" Ring Grease Seals with #498 009-J "O" Ring - Grease Seal.

SERVICE



BULLETIN

OLIVER OUTBOARD MOTORS

DIVISION OF OLIVER CORPORATION

108 SOUTH McCAMLY STREET • BATTLE CREEK, MICHIGAN

June 26, 1958

SM-1-34

TO: All Oliver Outboard Motor Distributors and Dealers

SUBJECT: Replacement of Lost Ignition Keys, 35 HP B Motors

The Service Department has had numerous requests for replacement ignition keys. It is impossible to furnish the correct key without the number of the key requested. This number appears on the key only and not on the switch. If the key is lost, and the numbers have not been recorded the number is lost also.

The factory recommends that the number on the key be obtained when the motor is sold and written on the warranty card along with the serial number of the motor. In this way a record can be kept of the key number with the serial number of the motor. In the event the key is lost, a duplicate key can be furnished if the serial number of the motor is furnished.

This is an added service to your customers that should pay dividends in good will and better service to your customers.

There are some 700 key combinations for the switch supplied with the motors. It is easy to see why the distributors are not asked to carry a full assortment of replacement keys.

SERVICE



BULLETIN

OLIVER OUTBOARD MOTORS

DIVISION OF OLIVER CORPORATION

108 SOUTH McCAMLY STREET • BATTLE CREEK, MICHIGAN

SM-1-31
6-25-58

TO: All Oliver Outboard Motor Distributors and Dealers

SUBJECT: Supplement to Bulletin SM-1-31
Installation Instructions for Counter-Rotating
Propeller Kit, Twin 70 H.P. Oliver Motors

To provide greater speed and better maneuverability please change Bulletin SM-1-31 to Mount #1 Motor with Right Rotation Propeller on Starboard Side and #2 Motor with Left Rotation Propeller on Port Side.

Use drawing on Page #4 of Service Bulletin SM-1-30 Installation of Drive Shaft Extension Kit for reference when using Service Bulletin SM-1-31 Installation Instructions for Counter-Rotating Propeller Kit.

C-3955A-50-1

SERVICE



BULLETIN

OLIVER OUTBOARD MOTORS

DIVISION OF OLIVER CORPORATION

108 SOUTH McCAMLY STREET • BATTLE CREEK, MICHIGAN

SM-1-31
5-27-58

TO: All Oliver Outboard Motor Distributors and Dealers

SUBJECT: Installation Instructions for Counter Rotating Propeller Kit,
Twin 70HP Motors.

The counter rotating propeller kits are now available, listed under Part #460 502JS Counter Rotating Propeller Kit, Kit includes following list of parts.

1	#460 460J	Shift Rod-Upper
1	460 461J	Gear Shift Handle
1	460 490J	Propeller Assy.-R.H. Rotation
1	460 491J	Propeller Assy.-L.H. Rotation
1	460 458J	Bell Crank
1	460 076J	Gasket-D/S Hsg. to Lower Shroud
1	460 173J	Groove Pin-Shift Handle
1		Installation Instruction Sheet

Installation of the counter rotating propeller kit will entail the removal of the power head from the engine designated as #1. The normal rotation of the propeller on Oliver Motors is left hand or counter clockwise. To get the proper perspective, take a position behind the motor as the motor would be mounted on a boat. The right and left hand of the motor is your right and left hand as you face the motor in this position. It is important to know which is the right or left hand as reference will be made to the right or left hand side of the motor. Also the direction of rotation of the propeller is from this same position. Right hand rotation is clockwise, that is the same position as the hands rotate on the face of a clock. Left hand rotation is counter clockwise, that is in the opposite direction of the hands on the face of a clock. Counter rotation as used as a title of this kit, means that the two propellers turn in opposite directions of rotation.

1. To remove the power head of #1 engine, loosen the eight (8) screws or nuts power head to driveshaft housing, located under and outside the lower shroud. Remove the top shroud and remove the three (3) large cap screws, lower shroud to driveshaft housing located inside the shroud around the base of the motor block.
2. Lift the power head off the lower unit. This will give access to the bell crank and upper shift rod.

3. Remove the cover-shift adjust port. This is located on the lower left hand side of the driveshaft housing just above the cavitation plate.
4. Loosen and remove the upper jam nut-shift rod coupling.
5. Remove the retaining screw from bell crank-standard rotation. Slip the bell crank off the shaft of the shift handle.
6. Push the entire shift rod linkage down to the normal reverse position. Lift the upper shift rod and shift rod coupling up disengaging the shift rod coupling from the lower shift rod. Turn the upper shift rod a quarter turn and force the end of the shift rod coupling out through the shift adjust port.
7. Unscrew the shift rod coupling and remove the coupling from the upper shift rod. This will permit removal of the upper shift rod.
8. Remove upper shift rod.
9. Remove the washers on the shift handle shaft and remove the shift handle. Make a note of the number of washers on the shift handle shaft and their location. The washers must be installed in the same location when re-assembled on the shift handle for counter rotating.
10. Remove the cotter key from propeller nut and unscrew the propeller nut. Knock out the shear pin and remove the standard propeller.

This complete the disassembly of all of the standard rotation parts. If a long shaft extension kit is to be installed on this motor, it will save time to install the extension kit at this time, before proceeding with the reassembly and installation of the counter rotation kit.

11. Drive the loose groove pin which comes with the kit into the hole in the gear shift handle. This may come assembled. Support the handle so that handle will not be damaged.
12. Place the washers on the shift handle shaft in the same order as removed in step #9 and insert the shift handle shaft through the bearing hole in the driveshaft housing.
13. Assemble the counter rotating bell crank to the counter rotating upper shift rod, using 1/8" cotter pin with the flat side of the bell crank-counter rotating down when the upper shift rod is installed on the motor. The rod and bell crank will be in the form of a letter "Z". The flat or straight side will be down. Refer to illustration bell crank-counter rotating.
14. Install the upper shift rod by running the shift rod down along the drive shaft. Force the threaded end out through the shift adjustment port. Screw the shift rod coupling on to the upper shift rod just far enough to permit the lower shift to pass freely through the hole in the shift rod coupling.
15. Place the shift rod coupling on the lower shift rod and start the jam nut, but do not tighten.
16. Install the bell crank on the shift handle shaft with the bell crank protruding forward of the shift handle shaft.
17. Start the bell crank retaining screw and tighten to a torque of 15 to 20 inch pounds. Use a center punch and stake the screw to prevent the screw loosening.
18. Replace the power head using a new gasket-lower shroud to driveshaft housing. Be sure the nylon roller is on the shift handle groove pin before replacing the power head as this cannot be installed after the power head has been replaced.

19. Adjust the shift rods at the shift rod coupling. Turn the lower jam nut down away from the shift rod coupling approximately three (3) turns. Place the shift handle in the forward position. This will move the shift rods downward. Joggle the propeller shaft to be sure clutch sleeve is fully engaged.

Use a screw driver and hold down on the lower shift rod. With the gear shift handle in forward position, turn the top jam nut so that there is $3/64$ " between the nut and the shift rod coupling. Move the gear shift handle to the reverse position and tighten the lower jam nut tight against the shift rod coupling. Be sure the lower shift rod does not turn when the lower jam nut is tightened.

20. Replace the cover-shift adjust port.
21. Replace the propeller using the right hand rotation propeller #460 490J and #1 motor is ready to be run and tested.
22. Number 2 motor - Remove the standard propeller and install the left hand rotation propeller from the counter rotating kit.

The motors are numbered from left to right, the same as when you read and write. You start at the left hand side of the page and move to the right. The port or left hand motor is the No. 1 motor. The starboard or right hand motor is the No. 2 motor. The motors as assembled at the factory will be marked port or #1 and Starboard or #2

The motor should be placed on the transom of the boat 22 to 24 inches from center to center of the motors. The minimum distance apart is twice the diameter of the propellers which would be 20 inches for 10 inch diameter propellers.

When rigging the steering cable, the cable must leave from the top side of the drum attached to the steering wheel. This is necessary to have the motors steer properly.

Measure from the forward edge of the remote control box location around the outside of the boat to the rear transom and across the transom to the center line of the nearest motor. That will be the required length for the shortest remote control cable. Add 1, 2, and 3, feet to this length for the other three cables. This method may be used for single motor installations. Add 1 foot to the length for the shorter cable. If this measurement is more than 3 inches over a foot, order the next actual full foot length.

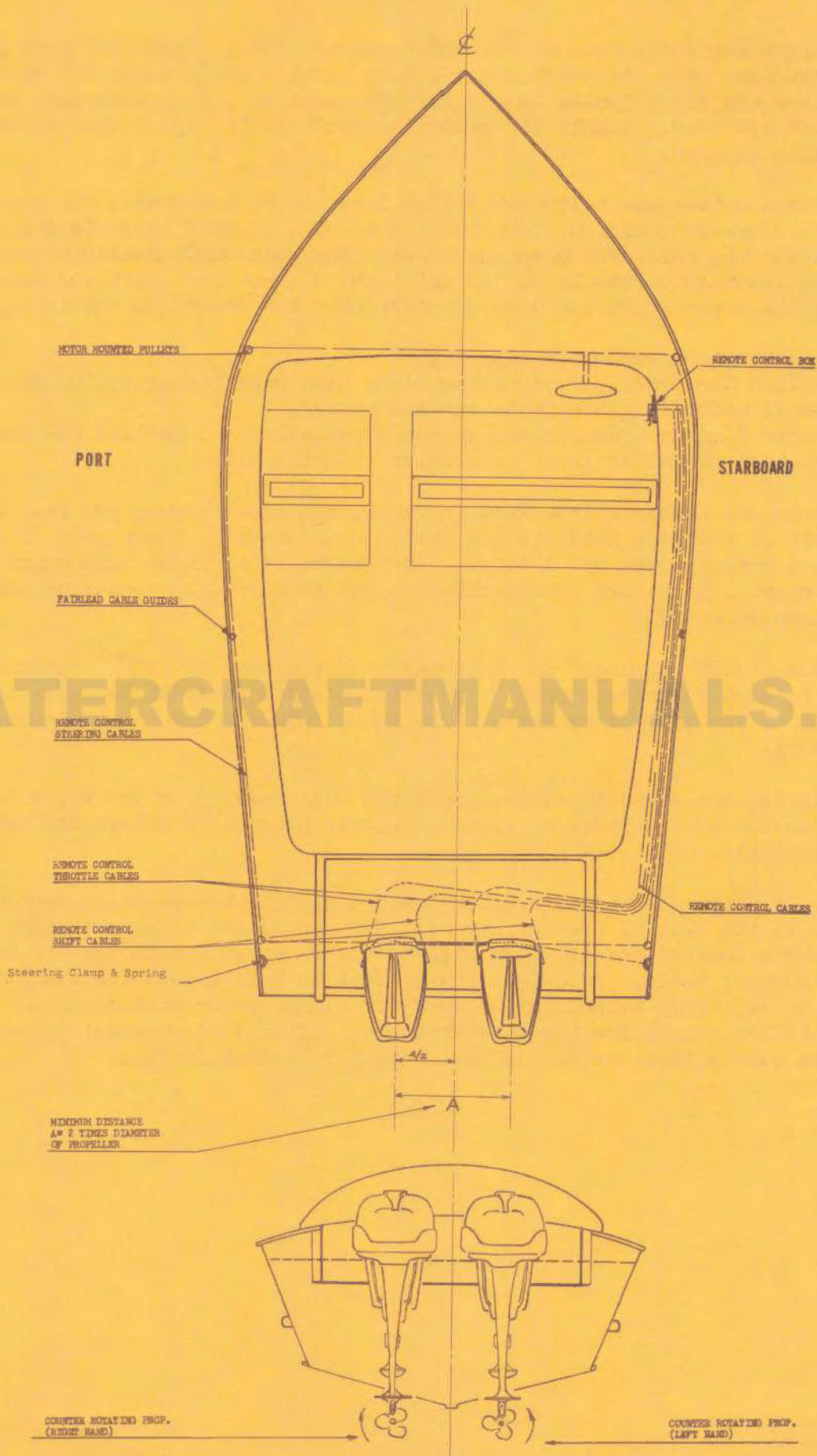

WATERCRAFTMANUALS.COM



OLIVER OUTBOARD MOTORS

DIVISION OF OLIVER CORPORATION

108 SOUTH McCAMLY STREET • BATTLE CREEK, MICHIGAN

SM-1-30

5-27-58

TO: All Oliver Outboard Motor Distributors and Dealers

SUBJECT: Installation of Drive Shaft Extension Kit

The 4-1/8" Extension Kits are now available listed under Part Number #467 302JS Kit, List Price \$25.75. Kit includes the following listed parts:

1	#460 441J	Housing-Extension
1	460 492J	Gear Shift Rod-Lower
1	460 443J	Drive Shaft-Extension
1	460 444J	Water Tube-Upper
4	AT 021	Screw-Ext. to Driveshaft Hsg.
4	920 082-1	Washer-Ext. to Driveshaft Hsg.
1	908 333-1	Screw-Ext. to Driveshaft Hsg.
1	920 083-1	Washer-Ext. to Driveshaft Hsg.

It will be necessary to remove the power head from the lower unit to replace the upper water tube.

- Loosen the (8) retaining screws or nuts-powerhead to driveshaft housing which are located under and outside the lower shroud. Remove the top shroud and remove the (3) large cap screws, lower shroud to driveshaft housing, located inside the shroud around the base of the block.
- Lift the power head off the lower unit.
- Remove the cover-shift adjust port, This is located on the lower left hand side of the driveshaft housing just above the cavitation plate.
- Loosen and remove the upper jam nut-shift rod coupling.
- Remove the (4) fillister head screws and (1) hex head cap screw retaining driveshaft housing to gear case. These screws will come out extremely hard, as a lock-tite solution is used to prevent these screws from coming loose. A socket screw driver bit for use with a 1/4" drive ratchet has been found most adaptable for removing these screws.
- Remove gear housing assembly from driveshaft housing.
- Place the gear housing assembly in a vise or some other devise to hold the gear housing in an upright position.
- Remove the (4) screws retaining water pump.
- Remove water pump assembly and drive shaft as a unit. This is accomplished by pulling up on the driveshaft. The shaft should come out easy.
- Install the longer shaft from the kit into the gear housing - CAUTION- Clean and oil the long shaft before installing. This is to prevent damaging the driveshaft seal. The shaft is installed by pushing the shaft through the seal turning the shaft to line up the splines with the clutch sleeve. The shaft will button on the lower driveshaft bearing.

11. Press the lower gear shift rod down and turn the propeller to be sure that the clutch sleeve has engaged the dogs on the reverse gear.
12. Loosen the brass seal nut on the shift rod. (2) screw drivers may be used or a tool may be fabricated from an 8" length of 3/8" steel pipe. File (2) notches in the end of the pipe to fit the slots in the brass seal nut. The seal nut is tightened only hand tight, therefore the soft steel pipe will be strong enough for this tool.
13. Start the (2) jam nuts on the lower shift rod. Tighten the (2) nuts together. This will lock the nuts on the lower shift rod. Use a 1/2" open end wrench on the lower jam nut. Turn the nut to the left or counter clockwise and unscrew the lower shift rod from the clutch yoke. This will take 12 to 14 complete turns.
14. Lift the lower shift rod up and out very carefully. Do not jar or shake the gear housing.
15. Remove the (2) jam nuts from the lower shift rod just removed and start the jam nuts on the longer lower shift rod packaged with the extension kit. Start the jam nuts on the rod end with the greater number of threads. Tighten the (2) jam nuts together to lock the nuts on the lower shift rod.
16. Remove the seal and brass seal nut from the lower shift rod. Place seal and brass seal nut on the longer lower shift rod. Place brass seal nut on first with the slots toward the jam nuts. Slide the rubber seal on the longer lower shift rod to approximately center of the rod.
17. Install the longer lower shift rod in the gear case where the shorter lower shift rod was removed. Base the shift rod down into place. Turn the shift to the right or clockwise. Do not force the rod down or the clutch yoke will be forced out of position. The end of the rod should start and screw into the clutch yoke easily 12 to 14 turns before turning hard. Use a 1/2" open end wrench on the top jam nut and torque to 20 to 30 inch pounds and remove the jam nuts from lower shift rod. NOTE: If for any reason the lower shift rod does not screw into the clutch yoke as outlined above, it will be necessary to disassemble the lower drive unit assembly. To accomplish this, drain the transmission oil, remove the (4) retaining screws, bearing carrier to gear housing. Remove the driveshaft and then lower drive unit assembly and clutch sleeve. Hold the clutch yoke in line with the lower shift rod and screw the rod into the clutch yoke. To reassemble, place the clutch sleeve in the clutch yoke. Check first to see that the dog teeth are set to engage the dog teeth on the pinion gears. If the clutch sleeve is placed in upside down, the clutch will not engage in either forward or reverse. Replace the drive unit and driveshaft. Torque retaining screws, bearing carrier to gear housing 90 to 110 inch pounds. Refill the transmission with 13 oz. SAE 90 Hypoid Oil.
18. Oil the lower shift rod seal.
19. Tighten the brass shift rod seal nut. With the seal well oiled the shift rod should move up and down with a force of 8 to 12 pounds. This force is given in pounds to help estimate the feel. Lift a 10 pound weight to get the feel. Move the lower shift rod and the feel should approximate lifting a 10 pound weight.
20. Separate the water pump cover from water pump body on the shorter drive shaft and remove them from the driveshaft.
21. Slide the water pump body down over the long driveshaft installed in the gear housing. Place the lower water tube into the inlet hole and grommet and slide both the lower water tube and water pump body into place together.

22. Remove the water pump impeller from the short driveshaft and place in on the long shaft. The driveshaft turns clockwise looking from the top down. The impeller goes on the driveshaft with the vane supports on the trailing side of the vane. The flat side of the impeller vanes are placed on the forward or leading side of the vanes. Turn the driveshaft clockwise with the impeller installed in the water pump body and you can easily tell which is the leading side of the impeller vanes.
23. Remove water pump pin from the short driveshaft and install the pin in the long driveshaft. Lift up the long driveshaft approximately $3/4$ " and slide the impeller over the water pump pin. Turn the driveshaft clockwise at the same time press down on both the impeller and driveshaft. This will force the impeller into the water pump body and the driveshaft into place.
24. Remove the water pump plate from the short driveshaft and install on the long drive shaft. The hole for the driveshaft is off center. Turn the plate so that it will match the water pump body.
25. Install a new water pump gasket.
26. Remove the water pump cover from the short driveshaft. Clean off the old gasket and install on the long driveshaft.
27. Replace the (4) screws. Water pump retaining and torque to 70" pounds.
28. Install the housing extension on the gear housing, using the (4) fillister head screws and (1) hex head cap screw. Torque the 5/16-18 fillister head screws to 70" lbs. Torque 3/8-18 hex head cap screw to 140" lbs.
29. Start the lower jam nut on to the lower shift rod and screw down approximately 1 inch.
30. Install the gear housing with the extension on the driveshaft housing using the screws removed in step #5. Torque the screws as in step #28.
31. Remove the rubber grommet from the short upper water tube and install on the long upper water tube.
32. Install the long water tube in the driveshaft housing and the water pump outlet.
33. Replace the power head.
34. Adjust gear shift rods at shift rod coupling per instruction for shift adjustment.
35. Replace the cover-shift adjust port removed in Step #3.

Reread and check off each step to see that you have not missed any. Motor should be ready to run and test.

BELL CRANK
COUNTER ROTATING
(RIGHT HAND ROTATION)

NOTE: FLAT SIDE OF
COUNTER ROTATING
BELL CRANK MUST
FACE DOWN

GEAR SHIFT HANDLE

BELL CRANK
STD. ROTATION
(LEFT HAND ROTATION)

SHIFT ROD
(LEFT HAND ROTATION)

SHIFT ROD
(RIGHT HAND ROTATION)

COUPLING-SHIFT ROD
AND TWO JAM NUTS

HOUSING EXTENSION
LONG UNIT ONLY

MISC. HARDWARE
LONG UNIT ONLY

WATER TUBE
LONG UNIT ONLY

COVER-WATER PUMP

BODY-WATER PUMP

WATER TUBE LOWER

DRIVE SHAFT
LONG UNIT ONLY

CLUTCH YOKE

GEAR SHIFT ROD-LOWER
LONG UNIT ONLY

CLUTCH SLEEVE

PROPELLER

WATERCRAFTMANUALS.COM

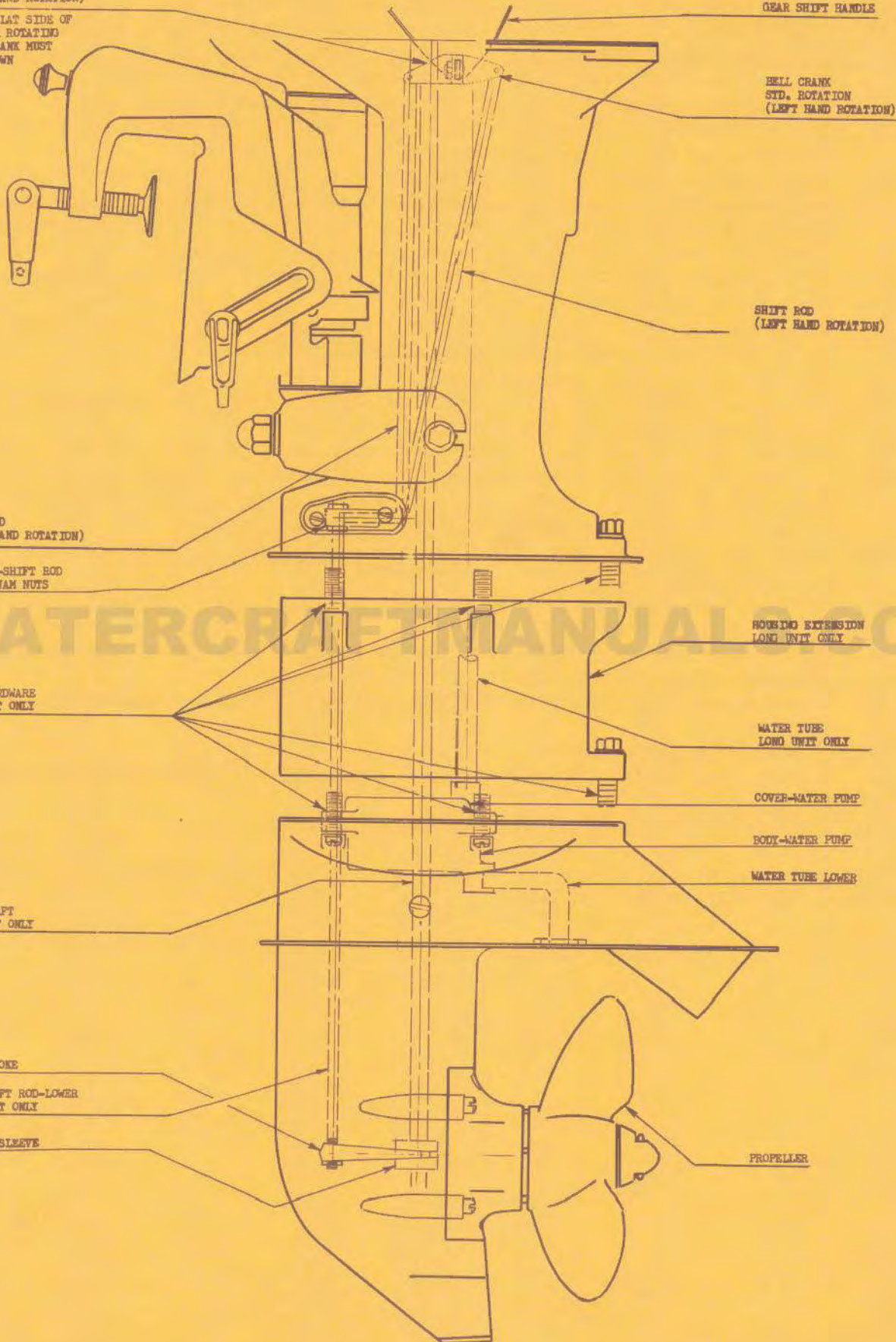



OLIVER OUTBOARD MOTORS

DIVISION OF OLIVER CORPORATION
108 SOUTH McCAMLY STREET • BATTLE CREEK, MICHIGAN

SM-1-29

5-27-58

TO: All Oliver Outboard Motor Distributors and Dealers

SUBJECT: Removal of Front Shroud and Replacement of 35 HP Model B, Carburetor.

It is necessary to remove the front shroud to gain access to the front accessories and carburetor.

1. Remove the upper shroud.
2. Remove the (2) #910 076-1 Screw-Front Shroud to Bracket, (2) #910 058-1 Screw-Front Shroud to Lower Shroud, (1) #910 060-1 Screw-Front Shroud to Lower Shroud. The #910 060-1 Screw is located on the lower side of the front shroud. To remove this, requires a 10 inch screw driver. A screw driver with a small diameter shaft has been found to be best for this operation.
3. Move the front shroud out approximately 2 inches and toward the shift handle side. This will give access to the #460 356J Male Receptacle and Cable Assembly.
4. Remove the (4) #910 225-1 Screw-Male Receptacle Retaining Screws.
5. Remove the #460 2 09J Fuel Hose-Pump to Disconnect from the fuel pump. This is the lower hose attached to the fuel pump.
6. Remove the front shroud from motor. This can be removed by moving the front shroud toward the shift handle side of the motor and pulling out away from the motor.
7. Remove (2) #CF 001 Snap Ring-Choke and Throttle Links.
8. Remove (2) #915 001-1 Nut-Carburetor Retaining.
9. Remove #460 208J Fuel Hose-Pump to carburetor.
10. Remove carburetor from motor.
11. Remove #460 273J Carburetor Gasket.
12. Remove Hi and Low speed knobs by loosening set screws.
13. Remove choke knob by turning counter clockwise. The choke rod is threaded.
14. Remove (2) #915 538-1 Nut-Silencer Retaining. These are the two nuts on the front of the air silencer.
15. Remove silencer front plate assembly.
16. Remove silencer screen.
17. Remove (2) silencer studs and choke hold down spring. The spring is mounted under the stud nearest the choke rod and will be on the silencer stud when it is removed.

18. Remove silencer back plate.
19. Remove (1) #CF 002 Snap Ring from choke rod.
20. Remove choke rod.
21. Remove overflow hose.
22. Remove 90° elbow fitting from carburetor fuel inlet.
23. Install carburetor in reverse order, using new #460 273J Carburetor Gasket. Set mixture control knobs at one full turn. Finer adjustment to be made when motor is operating.
24. Tighten nuts Item 8, carburetor retaining evenly. Do not exceed 100 inch pounds torque.

INSIDE VIEW FRONT SHROUD

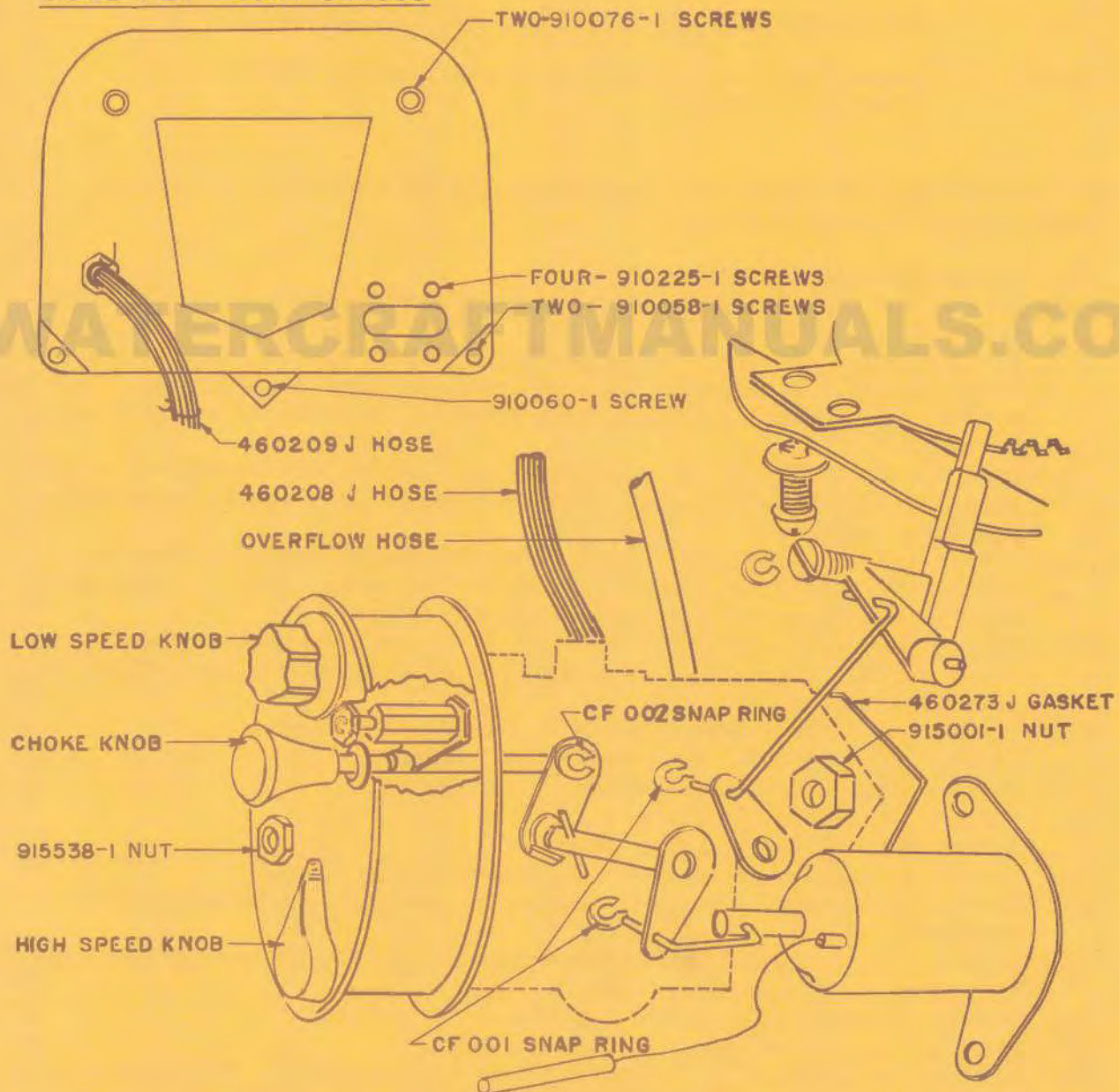



SERVICE

BULLETIN

OLIVER OUTBOARD MOTORS

DIVISION OF OLIVER CORPORATION

423 EAST MICHIGAN AVENUE • BATTLE CREEK, MICHIGAN

TO: All Distributors and Dealers

SM-1-24
12-6-57

SUBJECT: Conversion of Push Type to Pull Type choke on
K2 and K2E Motors.

We now offer a kit to convert push type to a pull choke which aids in starting the K2 and K2E motors. This kit is listed as Part #498 428J and lists at \$2.27.

The Kit Includes:

1	#AH 005	Drive Screw #0 (.073) x 3/16
1	010930	Choke Pickup Lever
1	010931	Choke Pickup Lever Return Spring
1	492 377J	Choke Rod
1	492 418J	Spacer-Choke Rod
1	490 347J	Decal-Pull Choke

Modification Program

1. Remove the mixture control knob and the six (6) screws in the face of the shield.
2. Bend the hose clamps to loosen the pressure hose.
3. Remove the shield. It will still hang to the starter rope. The choke will be exposed.
4. Remove the two (2) screws in the choke shutter and remove it.
5. Remove the choke return spring and pull the choke pickup lever shaft out of the carburetor.
6. Remove the choke pickup lever (010689) from the shaft and replace with (010930) choke pickup lever and (010931) choke pickup lever return spring.
7. Drill a 1/16" hole, 1/8" deep in the body of the carburetor 1/4" above the pin already driven in the body for the choke shutter stop.
8. Drive the (AH 005) drive screw into the 1/16" hole.
9. Reassemble, fastening the choke pickup lever return spring to the AH 005 drive screw.
10. The pull choke decal #490 347J is a water decal. Remove the raised lettering on the shield and place decal on in that location.

The above modification will produce an arrangement similar to that used on our current models. It will naturally improve the ease with which K2 and K2E motors can be started. It is a good selling feature to offer Oliver owners.

Very truly yours,

THE OLIVER CORPORATION
Outboard Motor Division

R. D. Marine

R. D. Marine
Service Manager

RDM:dd

C-3955A-40



SERVICE

BULLETIN

OLIVER OUTBOARD MOTORS

DIVISION OF OLIVER CORPORATION

108 SOUTH McCAMLY STREET • BATTLE CREEK, MICHIGAN

SM-1-49
10-17-58

TO: All Oliver Outboard Motor Distributors and Dealers

SUBJECT: Factory Service Schools

We are pleased to announce our 1959 Factory Service School Program and schedule. So that we may give you thorough and complete training we have set up two courses.

1. Basic Course - Each student will be given an engine in each horsepower - one to be worked on each day. Under the supervision of an authorized instructor each motor will be completely disassembled and reassembled and tank test operated to insure the student of learning proper assembly methods and adjustments.
2. Advance Course - This will cover two cycle engine theory, the application of this in trouble shooting and the use of test equipment. Short cuts in repairing and trouble shooting including the use of special or reworked tools. We will cover all of the engineering changes on the 1959 models.

Each class will include a tour of our plant, giving you an opportunity to see the 1959 models in production.

The schedule for these courses are as follows:

- | | | | |
|-------------------------------------|----------|----------|----------|
| 1. <u>Basic Course</u> - November | 10-11-12 | December | 1-2-3 |
| | 17-18-19 | | 8-9-10 |
| | 24-25-26 | | 15-16-17 |
| 2. <u>Advance Course</u> - November | 13-14 | December | 4-5 |
| | 20-21 | | 11-12 |
| | | | 18-19 |

You will note that with the exception of the Basic Course which is offered the week of November 24th, that our schedule is arranged so that you may complete both courses in one week. Be sure and advise us if you want to complete both courses consecutively.

Successful completion of this course will result in receiving a diploma to display in your store, notifying the public that you are an authorized repair station with factory trained personnel servicing the Oliver Outboard Motors.

We must have your reservations at least two (2) weeks prior to the course you wish to attend. We will be very happy to make hotel reservations upon request. There is absolutely no charge for this school. All tools and necessary equipment will be furnished.

Service Department

WATERCRAFTMANUALS.COM

SERVICE



BULLETIN

OLIVER OUTBOARD MOTORS

DIVISION OF OLIVER CORPORATION

108 SOUTH McCAMLY STREET • BATTLE CREEK, MICHIGAN

SM-1-48
10-17-58

TO: All Oliver Outboard Motor Distributors and Dealers

SUBJECT: Material Returns

This is to advise you that effective November 1st we have established a new claim procedure with regard to the return of merchandise from the field to the factory.

Any material which you believe should be returned to the factory must first be returned to your distributor for inspection who in turn will determine if it should be returned to the factory for further inspection and disposition.

Our Receiving Department has been instructed not to accept any shipments other than those from our Distributors.

Material should not be returned to your distributor until he has given you authorization to do so.

We are confident that this new procedure will expedite the handling of returned merchandise, will give you better service and keep all records in accord at the Dealer, Distributor and Factory level.

Service Department

C-3955-A68

SERVICE



BULLETIN

OLIVER OUTBOARD MOTORS

DIVISION OF OLIVER CORPORATION

108 SOUTH McCAMLY STREET • BATTLE CREEK, MICHIGAN

September 17, 1958

SM-1-47

TO: All Oliver Outboard Motor Distributors and Dealers

SUBJECT: Oliver Special Formula - Outboard Lubricant

The Oliver Outboard lubricant has been released to the field last May.

A substantial quantity has been sold, and the results have been very satisfactory. All users invariably have proven by actual test that it is an outstanding product.

Reports from the field have proven, in addition to our laboratory tests, that four (4) ounces of Oliver outboard lubricant mixed with each gallon of regular grade gasoline does improve the performance of any outboard motor.

Display it and sell it with confidence, knowing that your customer will come back for repeat orders again and again.

The product sells itself, because it definitely contributes to easier starting less carbon deposits, less plug fouling, less port plugging, less smoke and without a shadow of doubt, much longer engine life.

This Oliver outboard lubricant is available through your distributor in 16 ounce cans, and comes packed twenty-four (24) cans to a case.

The suggested list price is \$.75 each 16 ounce can.

Shipments are made in the usual manner from your distributor with your usual discount applied.

The attached leaflet gives you additional information.

Do your customer a favor now! Sell them the Oliver Special Formula Outboard Lubricant.

Service Department

C-3955-A67

SERVICE



BULLETIN

OLIVER OUTBOARD MOTORS

DIVISION OF OLIVER CORPORATION

108 SOUTH McCAMLY STREET • BATTLE CREEK, MICHIGAN

SM-1-46
9-15-58

TO: All Oliver Outboard Motor Distributors and Dealers

SUBJECT: Gear Shift Adjustment - Model K2, K3 and K4 - 15 & 16 HP Motors

1. Place the gear shift handle in neutral position.
2. Check the distance between the gear shift handle and forward and reverse detent stop screws. This distance should be $17/64$ " between the gear shift handle and the forward stop screw; $11/32$ " between the gear shift handle and the reverse stop screw. The round shank of $17/64$ " and $11/32$ " drill may be used as a gauge. If this distance is correct, no adjustment of the stop screws is required. Proceed with Step #8. If the shift stop screws require adjustment it is easier to adjust the stop screws when the power head is removed. Make adjustment as follows:
3. Loosen the forward jam nut.
4. Turn forward detent stop screw in or out as required until the distance is $17/64$ " between the forward detent stop screw and the gear shift handle, when the handle is in neutral position.
5. Tighten the forward jam nut.
6. Loosen the reverse jam nut.
7. Turn reverse detent stop screw in or out as required until the distance is $11/32$ " between the reverse detent stop screw and the gear shift handle, when the handle is in neutral position.
8. Remove the four retaining screws that fasten the shift rod connector cover in place.
9. Remove the shift rod connector cover.
10. Loosen the set screw in the shift rod connector.

11. Place the gear shift handle in forward position.
12. Use smooth jawed pliers so as not to damage the lower shift rod. Raise the lower shift rod, at the same time joggle the propeller to be sure the clutch sleeve is fully engaged.
13. With the gear shift handle in forward position, and the lower shift rod raised to its farthest extremity, tighten the shift rod connector set screw.
14. Check the gear shift adjustment. The gear shift handle should hit the forward and reverse stop screws when prop is turned and clutch sleeve is fully engaged. Use a light twisting pressure on the propeller and move the gear shift handle slowly to the neutral position. The clutch sleeve should disengage when the gear shift handle reaches the neutral detent notch.
15. Check reverse shift adjustment same as for forward.
16. The lower gear shift rod has a total up and down movement of $3/4$ inches. Neutral is at the center or $3/8$ " plus or minus $1/32$ " from either forward or reverse. This can be measured by moving the shift handle to reverse position. Mark the lower shift rod with a soft lead pencil at the top of the shift rod tube. Move shift handle to neutral and mark rod. Move shift handle to forward and mark rod. This will give the actual movement of the lower shift rod. If everything checks as outlined, gear shift is properly adjusted. If not, see the following problems and suggested corrections.

Problem: Gear shift handle does not hit forward stop screw when set $17/64$ " from gear shift handle.

Cause: Gear shift rod connector is hitting driveshaft housing which prevents full upward movement of upper shift rod and connector.

- Correction:
1. Remove gear shift connector cover plate.
 2. File the driveshaft housing to permit full upward movement of the upper gear shift rod and connector.
 3. Loosen shift rod connector set screw and repeat Steps 11, 12, 13 and 14 above.

Problem: Gear shift handle goes past neutral notch before clutch sleeve disengages when handle is moved from forward to reverse positions.

Cause: Looseness in gear shift linkage.

Correction: Loosen gear shift bell crank retaining screw.

Problem: Worn gear shift bell crank.

Correction: Remove power head and replace bell crank. Note:- If retaining screw is loose always check bell crank for wear. Worn bell crank cannot be tightened and the screw will break.

Problem: Worn clutch yoke.

Correction: Replace clutch yoke.

Problem: Rivet loose in clutch lever assembly.

Correction: Remove clutch lever assembly and tighten or replace rivet.

Problem: Hole worn oversize in clutch lever assembly.

Correction: Replace clutch lever assembly.

Problem: Loose or worn clutch lever pin.

Correction: Tighten or replace clutch lever pin.

Problem: Gear shift connector loose on upper shift rod.

Correction: Replace connector

Problem: Hole worn in lower shift rod.

Correction: Replace lower shift rod.

Problem: Set screw not tight in shift rod connector.

Correction: Tighten set screw.

Problems and corrections are listed in sequence with most frequent listed first.

Problem: Gear shift handle goes past neutral notch before sleeve disengages from one position only; either forward or reverse. Gear shift not adjusted properly.

Correction: Readjust gear shift per instructions.

Problem: Clutch lever assembly bent out of shape.

Correction: Replace clutch lever assembly.

15 & 16 H. P. GEAR SHIFT ADJUSTMENT
ILLUSTRATION NO. 1

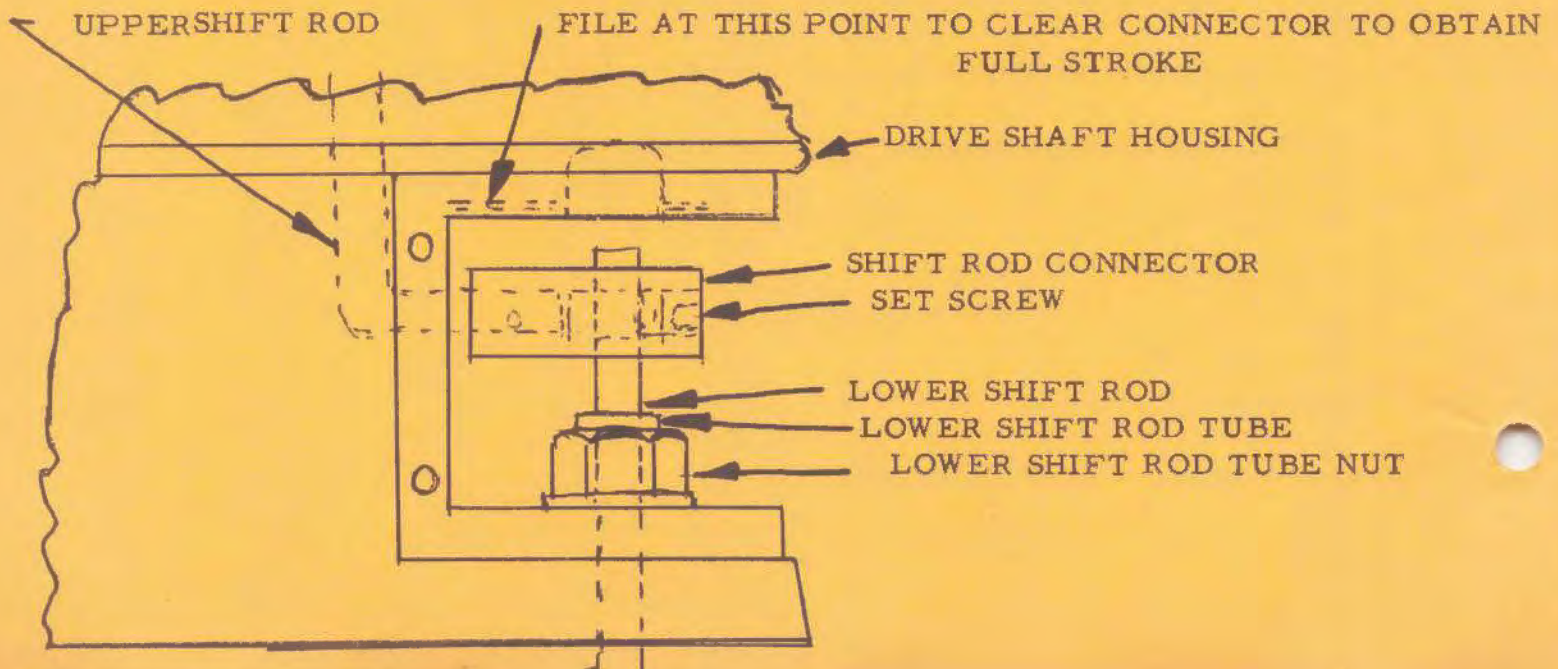
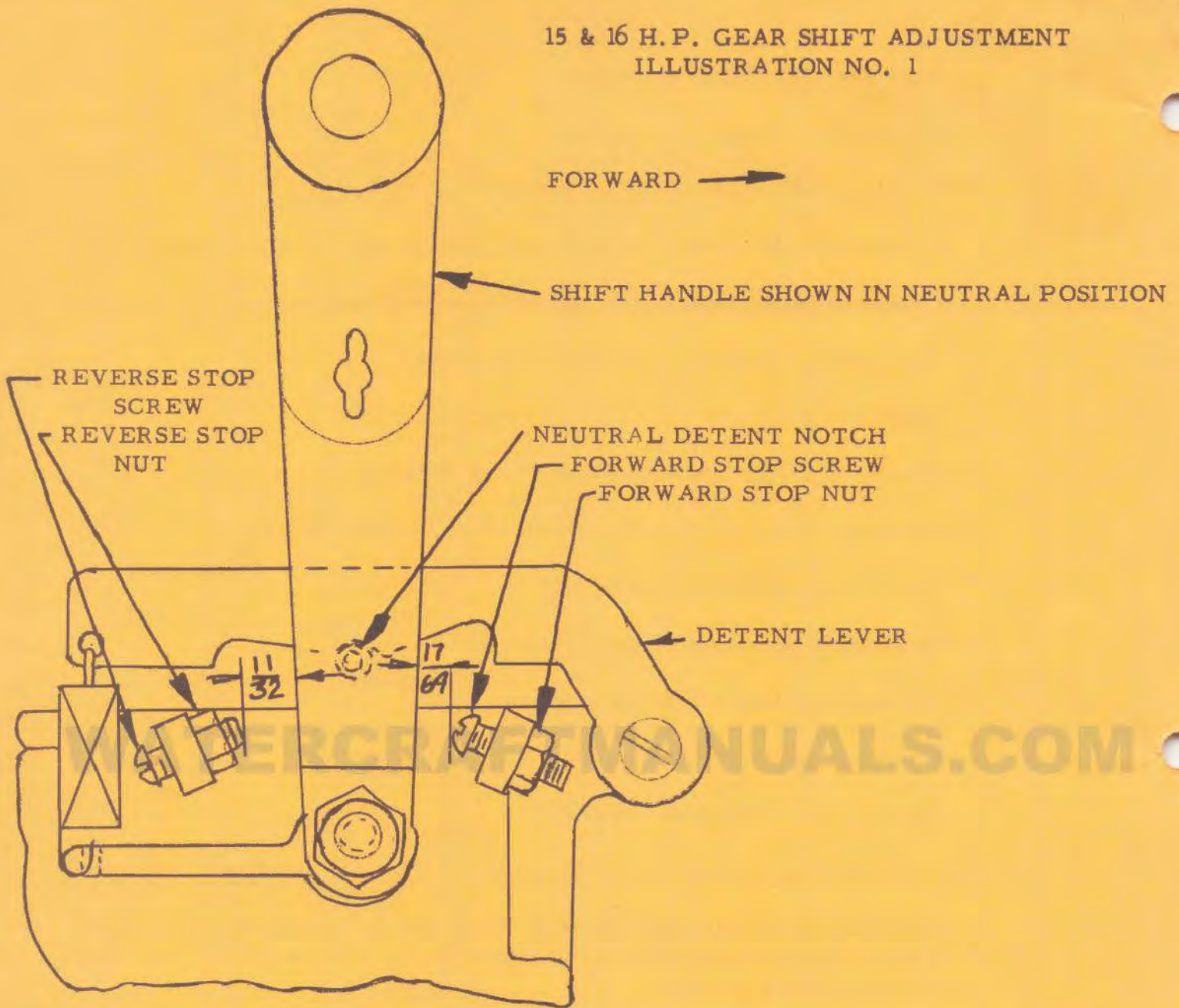



OLIVER OUTBOARD MOTORS

DIVISION OF OLIVER CORPORATION

108 SOUTH McCAMLY STREET • BATTLE CREEK, MICHIGAN

SM-1-45
9-15-58

TO: All Oliver Outboard Motor Distributors and Dealers
SUBJECT: THROTTLE LINKAGE AND CAM ADJUSTMENT - MODEL K, 15 and 16 HP

1. The carburetor sketch shows approximately the correct setting of the throttle linkage. The throttle lever is set 5° to 10° above the center line of the carburetor as illustrated. A long slim screw driver $1/4"$ x $10"$ shaft is best for making this adjustment after carburetor is installed on motor. Run the screw driver up between the lower shroud and carrying handle to loosen and tighten the throttle lever clamp screw.

2. Move throttle to idle position where the throttle cam follower will contact the throttle cam $1-1/8"$ from idle end of cam.

3. Loosen the throttle lever link screw.

4. Use the forefinger and press the cam follower lightly against the throttle cam. Be sure the throttle lever link is straight in the hole to prevent binding. Tighten the throttle lever link screw.

5. Move throttle to high speed position and check the clearance, between the cam and cam follower. This should be $1/32"$. If this clearance is less than $1/32"$ loosen the throttle lever screw and move the throttle lever up to full 10° above center line of the carburetor, and readjust throttle link. If the clearance is more than $1/32"$ move the lever down to 5° above center line of the carburetor and readjust throttle link.

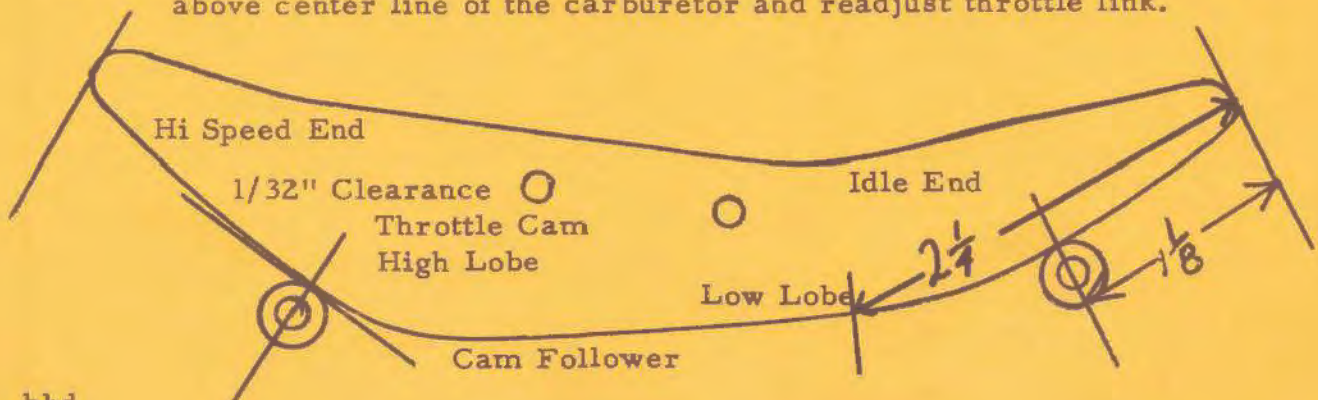
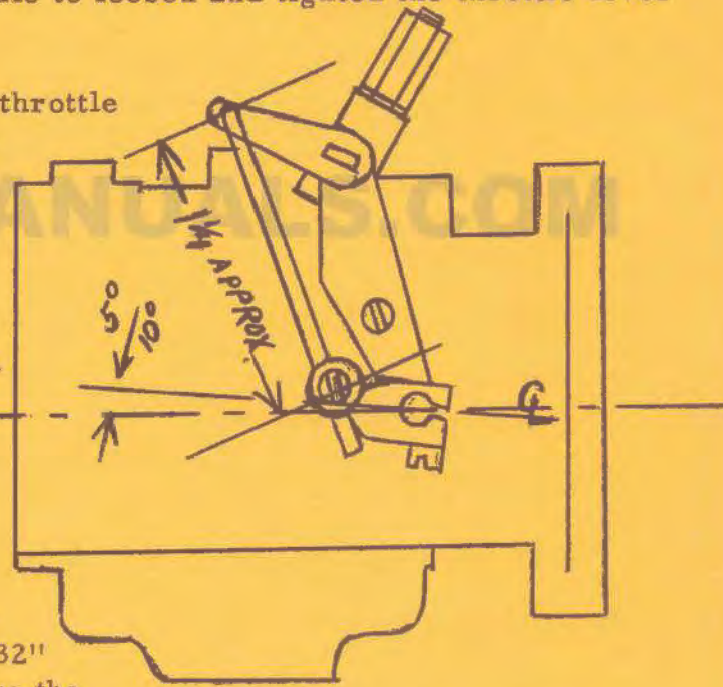

Throttle Linkage and Cam Adjustment
Model K, 15 and 16 HP Motors (Continued)

6. Move twist throttle control to stop position. Move shift handle to neutral position. Move twist throttle to start position, and on toward the fast position until further throttle advance is restricted by the stator plate stop contacting the throttle interlock.
7. Check the location of the cam follower. The correct start position of the cam follower is 2-1/4 inches from the idle end of the throttle cam. See drawing of throttle cam.
8. Adjust stator plate stop located under the flywheel on the magneto stator plate near the shift handle, for correct start position of the cam follower. The stator plate stop has slotted holes for adjustment. Loosen the two (2) stator plate stop retaining screw and move the stator plate stop to obtain correct start position. If the slotted holes do not permit sufficient adjustment, file a notch in the stator plate stop to obtain correct cam follower start position.

WATERCRAFTMANUALS.COM

C-3955-A65



OLIVER OUTBOARD MOTORS

DIVISION OF OLIVER CORPORATION

108 SOUTH McCAMLY STREET • BATTLE CREEK, MICHIGAN

TO: All Oliver Outboard Motor Distributors and Dealers

SM-4-44
9-15-58

Subject: Reworking of Manual Starter Side Support Bracket.

Model K-3 and K-4 Oliver Motors.

Serial Number K-200 720 to 201 800

Serial Number KE-275 108 to 275 500

Subject motors have the large diameter manual starter installed. These were installed to make the Model K's easier to start. The large diameter starter gives less clearance between the starter and the upper shroud. The upper shroud must be properly adjusted or the starter support bracket will hit the upper shroud with the possible damage to the upper shroud. To help prevent damage to upper shroud, the factory suggests the following:



ILL.#1

1. Remove the upper shroud assembly and check for starter brackets hitting the upper shroud. The upper shroud will be marred inside at the point of contact if the starter brackets have been hitting the upper shroud.

2. Measure the length of the side starter brackets as illustrated. The length should be 6-3/8 inches.

3. If the side starter support brackets are found to be longer than 6-3/8", remove the brackets from the motor and cut off the top of the bracket to the desired length. File or grind the top end round as illustrated. ILL#2. This will give a greater clearance between the bracket and upper shroud, and will leave no sharp edges to cut into the upper shroud. Paint the ends of the brackets to prevent rusting. Cutting the end off the bracket removes the rust proof plating and the bracket will rust if not painted.



ILL.#2

4. Reinstall the side starter support brackets using the new screws, part #490 400J Screw-Starter to Support. This screw is a 1/4-20 x 5/8" Truss Head Phillips Screw, and is shakeproof. No lock washer is required with this screw. The screw will give approximately 1/8" greater clearance between the upper shroud and the side starter support bracket screw. These screws, part #490 400J will be furnished on a "no charge" basis, quantity two (2) per motor, upon request to factory, stating the quantity required and serial numbers of the motors.

Reworking of Manual Starter Side Support Bracket (Continued)

5. Before replacing the upper shroud check the adjustment of upper shroud rear bumpers. (For a pictorial view of referenced parts turn to Page 2 of the Oliver 16 HP Outboard Motor Parts List, Model K-4). Reference #8, upper shroud assembly, is the rear bumper. Measure the distance between Ref. #10 rear bumper screws. This distance should be 9-1/4 inches. If the distance is other than 9-1/4 inches, it will be necessary to adjust the rear bumpers.
6. Remove the Ref. #6 and #7 rear bumper plates by loosening Ref. #12 screws, bumper plate to shroud.
7. Loosen Ref. #10 rear bumper screw enough to permit moving the rear bumper in and out. The hole is slotted to permit use of the rear bumper plates with aluminum or fiber glass upper shrouds.
8. Move the rear bumper out toward end as far as the slotted hole will permit and tighten the rear bumper screw. This is the correct location when the rear bumper plate is to be installed on a fiber glass upper shroud. For use on the aluminum upper shroud, move the rear bumper in as far as the slotted hole will permit and tighten rear bumper screw.
9. Attach the rear bumper plates to the upper shroud using the screws, bumper plate to shroud. Start the nuts on the screw only finger tight.
10. Place the upper shroud on the motor with the front of the shroud against the bumper shield to shroud. Grip the upper shroud and rear carrying handle with the left hand. Force the upper shroud into the groove in the bumper shield to shroud. At same time, with other hand, use a screwdriver handle and tap the rear bumper plates fore and aft until the rear bumpers are seated in the cone shaped hole in the rear carrying handle. Hold the upper shroud in this position and tighten the bumper plate to shroud screws.
11. Fasten the shroud latches. These should operate easily by hand, if the rear shroud bumpers have been properly adjusted. The upper shroud should not be distorted when latched into place.
12. The large diameter starter is adaptable to all Oliver Model K outboard motors.

Following is the list of parts required to change to the large diameter starter:

1	#490 398JS	Rewind Starter Assembly	\$ 19 .75
2	#492 445JS	Bracket-Side Starter Support	.35
1	#490 394J	Rear Starter Leg	.20
4	#490 400J	Screw-Starter to Support	.08



OLIVER OUTBOARD MOTORS

DIVISION OF OLIVER CORPORATION

108 SOUTH McCAMLY STREET • BATTLE CREEK, MICHIGAN

SM-1-43
Aug. 22, 1958

TO: All Oliver Outboard Distributors and Dealers

SUBJECT: Adjusting Throttle Arm on Carburetor to Throttle Cam Model J - 5 $\frac{1}{2}$ and 6 HP.

1. This bulletin is being circulated so as to improve the idle setting on the "J" model engines.
2. The throttle arm on the carburetor should drop off the throttle cam at approximately one (1) inch from the low speed end of the cam. See drawing below.
3. To adjust the throttle arm, loosen the throttle arm clamp screw enough to rotate the throttle arm on the throttle shaft, but tight enough to operate the throttle.

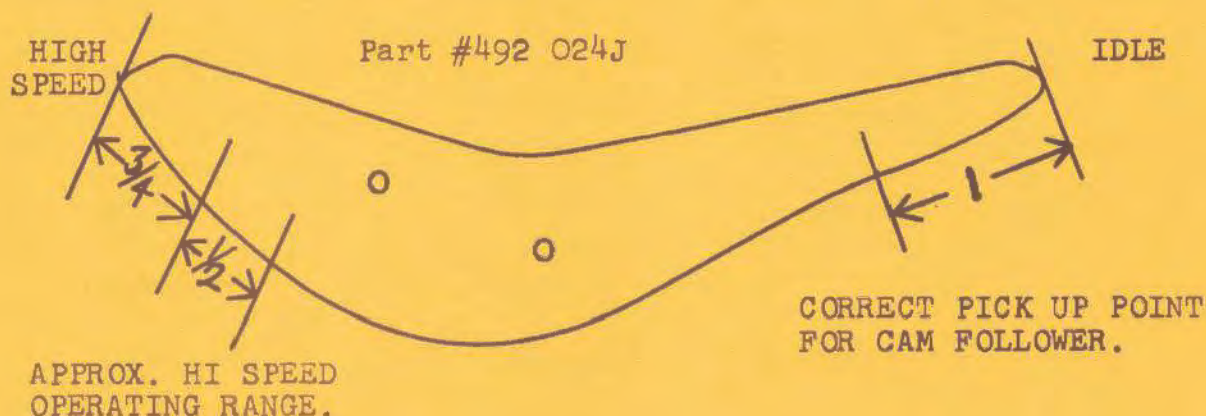

4. Operate throttle and move the throttle arm until throttle cam contacts the throttle arm one (1) inch from the idle end of cam.
5. Tighten the throttle arm clamp screw securely.



OLIVER OUTBOARD MOTORS

DIVISION OF OLIVER CORPORATION

108 SOUTH McCAMLY STREET • BATTLE CREEK, MICHIGAN

SM-1-42

Aug. 22, 1958

TO: All Oliver Outboard Distributors and Dealers

SUBJECT: Fuel Coupling Failure, 1958, J4, K4, and B2

The factory recommends changing the washer Ref. #2 in all the Aluminum Fuel Couplings.

The use of the wrong material in the washer, Part #498 115J in the fuel coupling assembly Part #498 336JS is the cause of the failure. The washer swells when in contact with gasoline and will partially or completely close the fuel passage in the coupling. Disconnecting and connecting the fuel coupling can shear off small pieces of the washer. These small pieces of washer may enter the fuel lines and clog the fuel pump screen or the jets in the carburetor. This can cause a very serious service problem.

Disassemble as shown in the drawing below and replace the washer. The factory will furnish #498 115J Washers at no-charge.

